

Softstarter Bypass Technology

Use a softstart bypass, either internal or external, to allow an application to run continuously after the start in a closed contactor mode and to open once a stop or fault command has been provided. Some softstarters are fully solid state, meaning no bypass is needed or included and are IEC rated AC-53a for running continuously on a squirrel-cage motor. Other softstarters are hybrids, which means that they are rated AC-53b intermittent duty and use a bypass when the motor is up to speed. This document discusses hybrid softstarters.

Table of Contents

Utilization Codes3

Internal Bypass Softstarter (Hybrid Softstarter)4

External Bypass6

Emergency Bypass.....7

Sizing the External Bypass Contactor9

Conclusion10

Utilization Codes

This publication discusses various suggestions for utilization codes. Table 1 explains the ratings and what they mean. Bypass contactors usually use categories AC-1 or AC-3.

Table 1 - Utilization Category Determination

Test Conditions		Making			Breaking			
		I/I_e	U/U_e	$\cos \phi$	I_c/I_e	U_r/U_e	$\cos \phi$	
AC-1	Resistance Furnaces: Non-inductive or slightly inductive loads	1	1	0.95	1	1	0.95	
AC-2	Slip-ring motors: Starting and reversing	2.5	1	0.65	2.5	1	0.65	
AC-3	Squirrel-cage motors: Starting and stopping of running motors	$I_e < 17 \text{ A}$	6	1	0.65	1	0.17	0.65
		$I_e > 17 \text{ A}$	6	1	0.35	1	0.17	0.35
AC-4	Squirrel-cage motors: Starting, plugging ❶, inching ❷	$I_e < 17 \text{ A}$	6	1	0.65	6	1	0.65
		$I_e > 17 \text{ A}$	6	1	0.35	6	1	0.35
AC-15	Solenoids: Contactors, valves, and lifting magnets	10	1	0.7	1	1	0.4	

❶ Plugging is understood as stopping or reversing the motor rapidly by reversing motor primary connections while the motor is running.

❷ Inching (jogging) is understood as energizing a motor once or repeatedly for short periods to obtain small movements of the driven mechanism.

I_e Rated operational current

I Making Current

I_c Breaking Current

U Off-load voltage

U_e Rated voltage

U_r Recovery voltage

Softstarters use AC-53a and AC-53b IEC utilization codes. Examples are listed in the following paragraphs.

AC-53a:

Squirrel-cage motors; starting, running and stopping with electronic switching device.

Example: AC-53a:3.5-30:99-1

- 350% current limit
- 30 second start
- 99% On load factor
- One start per hour

AC-53b:

Squirrel-cage motors; starting and stopping with electronic switching device that is bypassed during runtime.

Example: AC-53b: 3.0-50:1750

- 300% current limit
- 50 second start
- Off-time must not be less than 1750 seconds between starts

Internal Bypass Softstarter (Hybrid Softstarter)

The internal bypass contactor is used after the softstarter has brought the motor up to speed. The algorithm of the softstarter determines when the motor is up to speed and at that time, transitions from silicon-controlled rectifier (SCR) control to the bypass contactor. Sprecher + Schuh Series PCS and Series PF are both hybrid softstarters, meaning they have the power structure of a solid-state starter and an internal bypass contactor.

Attributes of an internal bypass contactor allow the softstarter to operate cooler with the motor at speed compared to a fully solid-state starter. The form factor of a hybrid softstarter is typically smaller than that of fully rated SCRs with no bypass. The reason for this is smaller components are used to start and carry the load current. The SCRs are rated for intermittent duty (AC-53b). The internal bypass contactors are typically not fully rated (AC-3), because they are typically designed to not make or break load current. Table 1 shows the definition of the utilization ratings of the contactors.

With an internal bypass softstarter, you only need power and control wiring. You do not need to purchase any additional devices. Internal bypass on a softstarter is perfect for conveyors, fans, pumps and other applications where the current and speed does not change while at speed.

Figure 1 - Hybrid Softstarter Wiring

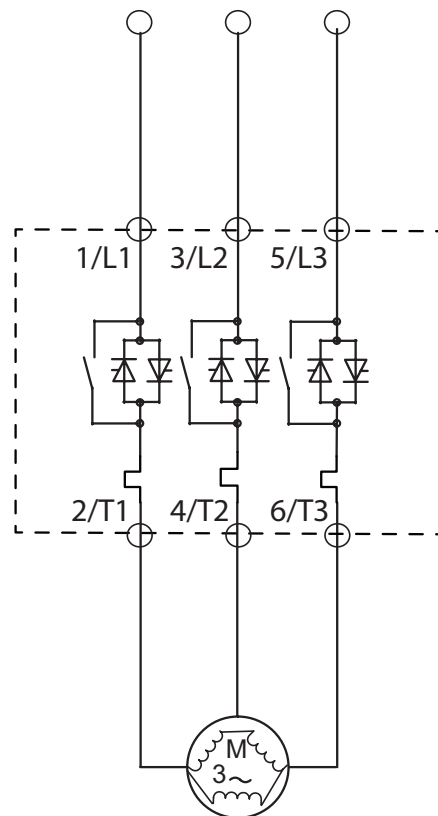

Fully Solid-State Softstarter Applications

A fully solid-state softstarter is designed to run an application, at full voltage and at speed, without the need or use of a bypass contactor after the start mode. The SCRs are fully rated at the amperage specifications of the softstarter including its AC-53a utilization rating.

Figure 2 - Solid-State Softstarter Wiring

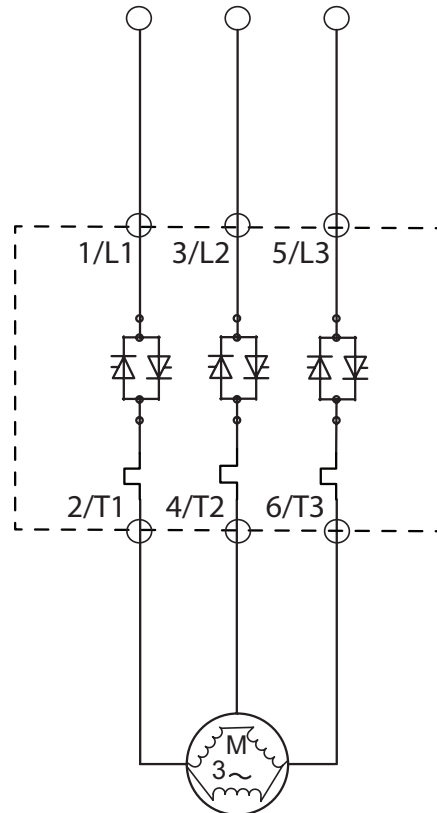

Fully solid-state devices are advantageous in harsh applications when there is a lot of vibration, dust, and dirt. Vibration is not a concern as it would be for an electromechanical bypass contactor, where it could potentially cause contact bounce.

Other applications for fully solid-state device include those in which there is a high duty cycle. Similar applications that use a solid-state contactor are possible candidates for the solid-state softstarter. The solid-state starter provides starting and stopping methods and feedback that a solid-state contactor would not be able to provide.

Solid-state softstarters have predefined ratings for normal duty and heavy duty. For example:

Utilization Categories Defined:

- Normal Duty Rating
 - AC-53a:3.5-10:99-2: 350% current limit, 10 second start, 99% ON load factor and 2 starts per hour; 40 °C ambient temperature rating
 - Ideal for Pumps and Compressors
- Heavy Duty Rating
 - AC-53a:3.5-30:99-1: 350%, 30 second start, 99% ON load factor and 1 start per hour; 50 °C ambient temperature rating
 - Ideal for harsh environments or more demanding applications (for example, chippers, rock crushers)

Applications not normally able to be done on a hybrid softstarter, such as motor heaters, resistive loads, and transformer loads, can sometimes be done using a fully solid-state softstarter.

External Bypass

Softstarters can use internal or external bypass contactors. Depending on the application, an external bypass may be a better choice than an internal bypass. In some cases, because of application considerations, a softstarter may have an internal bypass, but be configured to use auxiliary contacts/outputs to control an external bypass. The PF has that capability. Applications that are good for external bypass contactors are those where a soft start is desired, but while in run mode, current may spike due to product jams or plugging.

For example, in a rock crushing application, there is a high chance of jamming material in a hopper, causing spikes in current. A softstarter with an internal bypass contactor monitors current and may typically drop out of bypass to protect the contactor and return to SCR control. Once the current returns to normal, the bypass contactor is pulled back in. This cycling on and off could shorten the life of the internal electromechanical contactor.

Not having all protective features of the softstarter during the run mode may be a benefit to keep an application like rock crushing working. In that application, using an external bypass contactor that is fully rated to handle the current surges keeps the contactor pulled in until a stop command is given or an overload is tripped. External overloads may be needed to protect the motor because some softstarters may not be able to read motor data while in external bypass mode.

An external bypass contactor may also be used on an AC-53a-rated fully solid-state softstarter. Depending on both the softstarter and the mounting and wiring of the bypass contactor, there may or may not be a need for external overloads. The mounting features from the soft start to the bypass contactor dictate whether the softstarter will be able to read data (current and voltage readings) while in bypass mode. Figure 3 shows an example of a wiring diagram for an external bypass.

In UL/CSA regulated regions, size the bypass contactor according to the motor Hp and FLA. In IEC regulated regions, size the bypass conductor per the AC-1 rated bypass contactor rating.

The Hp ratings of the AC-3 rated bypass contactor must match the Hp ratings of the softstarter.

The short-circuit ratings of the bypass contactor must be similar to the softstarter. This is particularly important for the AC-1 rated bypass contactor selection.

Figure 3 - Line-connected Motor Wiring Diagram with External Bypass Contactor

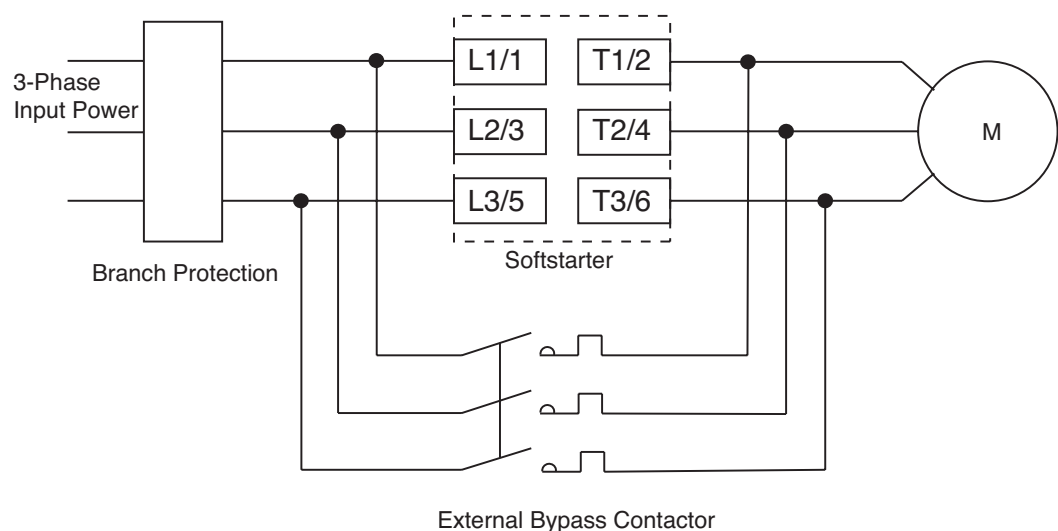
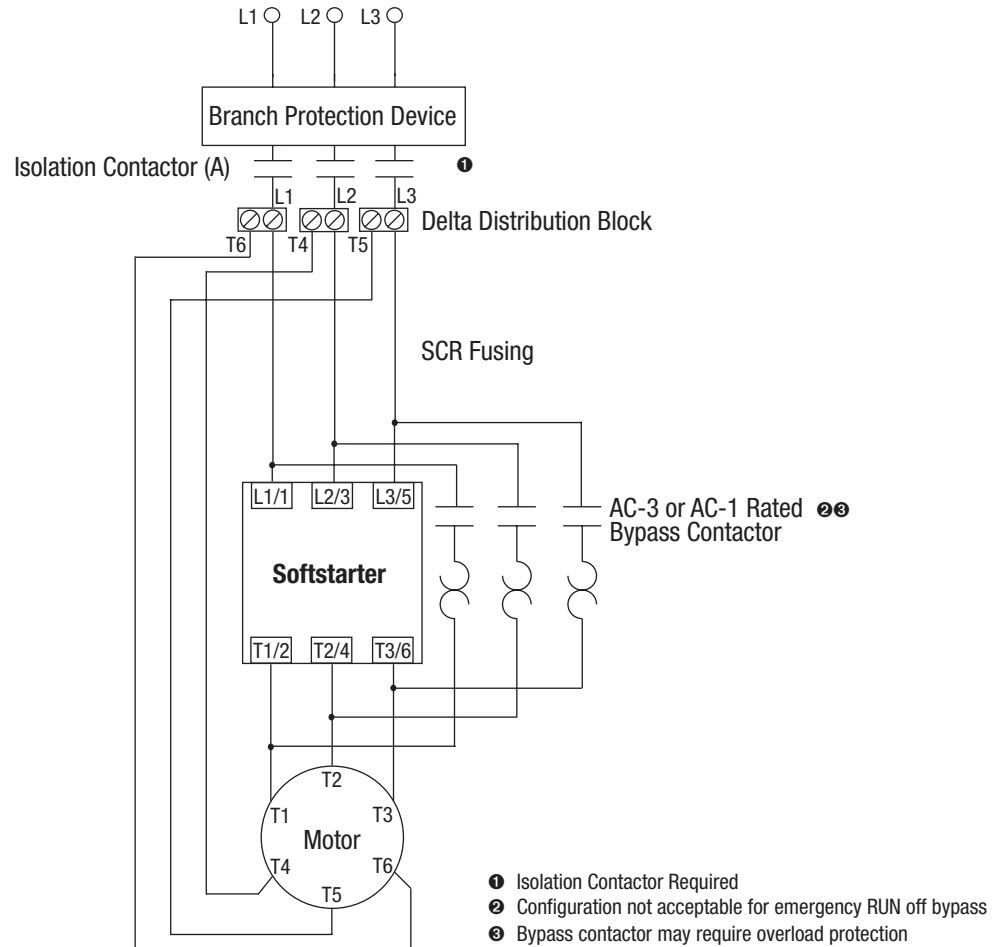

Figure 4 - Delta-connected Motor Wiring Diagram with External Bypass Contactor



Emergency Bypass

Emergency bypass is used when the softstarter will not be part of the starting or stopping circuit. Typically, a Hand-Off-Auto (HOA) switch is used to select between softstarter mode and emergency run control. An example is a critical application when a softstarter may have been damaged and needs to be replaced but the application still needs to run until the repair can be done, such as a municipal pumping application.

An emergency bypass contactor acts as an ATL (Across-the-Line) starter when energized. This contactor must be fully rated to a minimum of AC-3 Utilization Category rating to handle the inrush of the motor.

The emergency run bypass contactor is mounted external to the softstarter. This requires a larger foot print for the system. External overload protection to protect the motor while in emergency run is also required. The soft start has no control of that bypass contactor. The control circuit wiring needs to be implemented to energize the coil of the contactor.

Figure 5 shows a wiring example for the PF when using an emergency bypass. Note the PF Off-Bypass switch. This removes control from the softstarter. In this example, once the bypass is selected on the switch, the bypass contactor closes and the motor starts. You can add other buttons to achieve your desired level of control of start and stop functions.

Figure 5 - Typical Wiring Diagram for PF Softstarter Off-Bypass Control

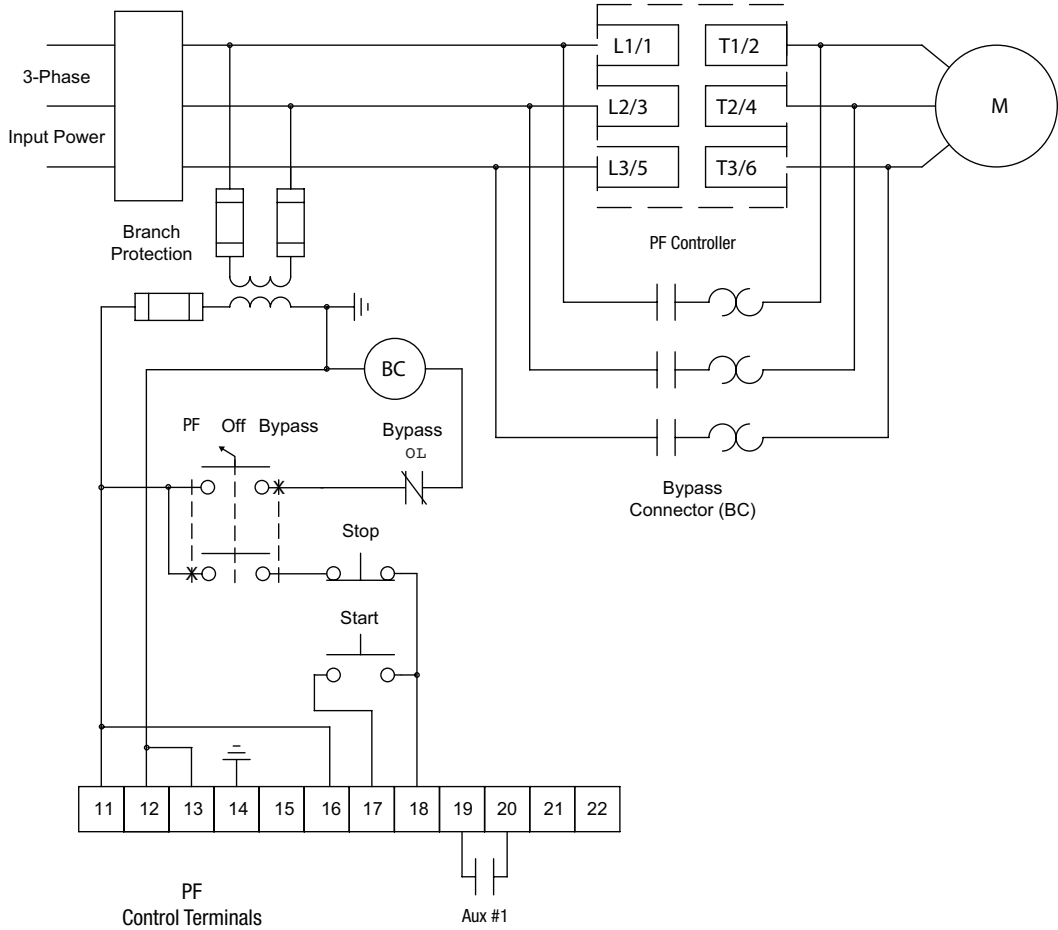

Sizing the External Bypass Contactor

In addition to the Utilization Rating of the PF softstarter, the total starting current of the motor should be taken into account if the bypass is to make or break motor current. Higher efficiency motors typically have higher starting current.

For example, if a high efficiency motor has a starting current of 10 times the FLA, the bypass contactor should be sized accordingly. A motor with full load amps (FLA) of 200 A should be calculated using the following equation:

$$(\text{FLA} \times \text{Inrush Multiple})/6$$

The denominator is 6 because the contactors are typically designed and rated to the utilization code of AC-3, which has a make characteristic of 6 times the FLA. See Table 1 on page 3.

In this example, the equation would be $(200 \times 10)/6 = 333.33$ A. The contactor for an AC-3 rating should be sized to handle a 333 A load.

ATTENTION: Always follow local codes when sizing components.

Some guidelines to follow when sizing an external bypass contactor include the following:

- An AC-1 rating is only sufficient if the SCRs of the softstarter are starting and stopping the load.
- If there is a chance of the bypass contactor making or breaking the motor load current, use a minimum rating of AC-3.
- If you are using the bypass in a rock crushing or similar type application, we recommend using at least an AC-3 rated contactor.

Conclusion

The fully solid-state softstarter has an AC-53a rating, which is the rating for continuous duty. The fully solid-state starter is well suited for harsh, dusty, vibration prone applications.

The hybrid softstarter is compact in form factor and usually operates cooler than a fully solid-state device of the same amperage size. The hybrid softstarter carries the AC-53b rating for intermittent duty. With the bypass contactor internal to the softstarter, wiring time and panel space is conserved.

Both the fully solid-state and the hybrid softstarter can typically use an external bypass if needed, if the softstarter has terminals that can be used for control and/or coordination of the external bypass.

Table 2 lists the relative advantages and disadvantages of each softstarter bypass type.

Table 2 - Internal Bypass compared to Solid-State Softstarters Advantages and Disadvantages

Internal Bypass (AC-53b Intermittent Duty Rated)	Solid-State Softstarter (AC-53a Continuous Duty)
Advantages	Advantages
Smaller footprint	Silicon-controlled rectifiers (SCRs) are fully rated for continuous duty
Less wiring	Longer life, no mechanical life limitations
Less heat dissipated	Ideal for critical performance in harsh environments
Optimized thermal management	Allows for specialized control
Lowest total installed cost	Higher operations per hour
—	Optional external bypass contactors
Disadvantages	Disadvantages
May need to replace whole power pole if there is damage to the bypass	Large foot print
Cannot be used to bypass PF/PCS for emergency use	Larger finned heat sinks and fans
Cannot select to use SCR control mode only	Produce more heat

When deciding which type of softstarter to use, you must carefully consider your application requirements, panel space, budget, and operating environment.



Sprecher + Schuh US Division Headquarters

15910 International Plaza Drive
Houston, TX 77032

Customer Service: (877) 721-5913
Fax: (800) 739-7370

Sprecher + Schuh Canadian Deivision

10 Spy Court
Markham, ON L3R 5H6

Customer Service: (905) 475-6543
Fax: (905) 475-0027

www.sprecherschuh.com



Softstarter Bypass Technology
White Paper

WP-SoftstarterBypassTech 06/16
150-WP0006A-EN-P

Sprecher + Schuh has provided reliable control and protection solutions for its customers since 1903.

Today, Sprecher + Schuh offers a wide range of low-voltage industrial control products, including contactors, a variety of relays, starters, push buttons, switches, terminals and controllers, to name a few. All of our products are crafted with precision and tested rigorously for performance — far exceeding industry standards. Moving forward, we continue along the path of constantly seeking innovative ways to provide solutions for our customers. It is by this philosophy that Sprecher + Schuh has come to be the industrial control manufacturer of choice for many customers around the globe seeking quality, reliability, and a name they can trust.