



*Methods of Applying*

**KT7**

## **Motor Circuit Controllers & Molded Case Circuit Breakers**

*This information is provided to aid in proper system design and utilization of the KTA7, KTB7 & KTC7 Motor Circuit Controller in North American applications. UL approved Molded Case Circuit Breakers (KTU7) are also explained.*

## Methods of Applying KT7 Motor Circuit Controllers

The KT7 Motor Circuit Controller provides Class 10 overload protection, as well as, current limiting short-circuit protection for individual motor loads. KT7s are also approved for use as circuit breakers (per IEC 947-6-2) for applications outside of North America. In the United States and Canada, however, they are UL/CSA listed as Manual Starters with optional approvals for Motor Disconnecting and Group Motor applications.

KT7 Motor Circuit Controllers are also UL/CSA listed as Self-Protected Combination (Type E) Starters, eliminating the requirement for additional short-circuit protection in many applications. This reduces both panel space and cost in multi-motor installations and eliminates the restrictive NEC/CEC rules that pertained to Manual Starters used in Group Motor applications.

The following information is provided to aid in proper system design and utilization of the capabilities of the KT7 Motor Circuit Controller in North American applications. *Please be sure to consider all applicable local and national codes for your particular installation.*

### Circuit Breaker Applications – IEC

KT7 Motor Circuit Controllers are current limiting IEC circuit breakers (IEC 947-6-2) that also provide Class 10 motor overload protection. Additionally, they meet IEC requirements for applications such as:

- Disconnect (IEC 947-2)
- Main Switch (IEC 204-1)
- Emergency Off (IEC 204-1)
- Revision Service Switch (IEC 947)

A KT7 Motor Circuit Controller cannot be applied in North America as a circuit breaker because it does not meet the UL specifications for circuit breakers (UL 489).

### Manual Starter Applications — UL/CSA

KT7 Motor Circuit Controllers are an excellent choice for manual starting applications. As UL/CSA listed manual motor controllers, they provide motor overload protection, however, a separate short-circuit protective device must still be used. The fuses or circuit breakers used for the short-circuit protection may be sized to the maximum allowable per NEC Article 430-52 in the U.S., and CEC Rule 28-200 in Canada. The KT7 as a manual motor starter is available in a general purpose enclosure, water tight enclosure, or Type 7/9 enclosure. Under-voltage or shunt trip relays are also available.

## Traditional Group Motor Applications UL/CSA

KT7 Motor Circuit Controllers are also UL/CSA listed as manual starters for use in Group Motor installations. This listing (and application) has been popular in the United States because of the reduced panel space and cost savings it provides.

NEC article 430-52 states that each motor must have a Branch Circuit Protective Device (BCPD) consisting of a fused disconnect, fuse block & set of fuses, or a circuit breaker. A typical circuit is illustrated in Figure 1.

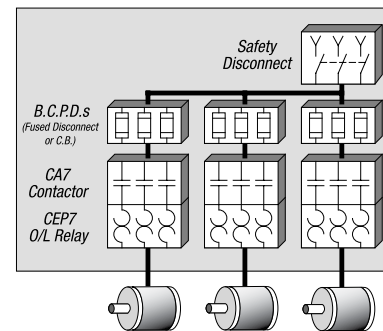

Figure 1  
Classic Group Motor Circuit (NEC 430-52)

Even though this method is highly effective and widely used, it has several drawbacks.

- Breakers or fuse blocks for each motor circuit are expensive
- The panel space required to house many components like this is substantial
- Installations of this type are labor intensive and therefore more costly

NEC 430-53 [CEC 28-206] however, provides several exceptions to 430-52 [CEC 28-204] that allow you to connect a group of motors under one BCPD. These exceptions can be found under:

- 430-53(a) - For Motors 1 HP or Less
- 430-53(b) - The Smallest Motor is Protected
- 430-53(c) - Other Group Installations

## Methods of Applying KT7 Motor Circuit Controllers

For example, Figure 2 illustrates how a circuit would look utilizing provision (a) or (b) above. What was once three branch circuits, with three BCPD's, is now one branch circuit with one BCPD.

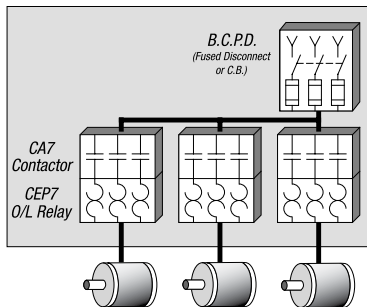

Figure 2  
NEC Article 430-53 circuitry without KT7

It appears that the exceptions in 430-53 address the expensive drawbacks to having one BCPD for each motor. Expensive fuses (or circuit breakers) have been eliminated. Panel space has been significantly reduced, as well as the labor to install the circuit.

Unfortunately, NEC 430-53 (a) or (b) [CEC 28-602 (3)(b)] limits the group to a few small motors. However, by applying the KT7 under 430-53 (c) (Figure 3), the problems associated with 430-53 (a) and (b) are overcome.

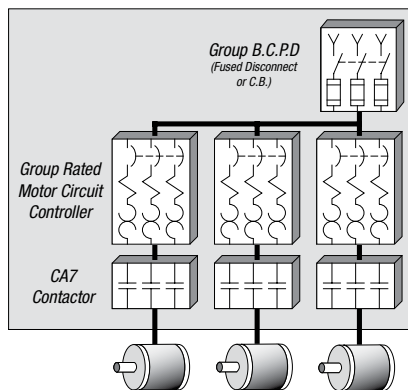

Figure 3  
Article 430-53C Circuitry With  
KT7, KTA3 or KT4

- Only one fuse block (or circuit breaker) is used as the BCPD
- Panel size has been significantly reduced
- Wiring and installation time has been significantly reduced
- We have assured protection against low level faults that the BCPD would pass
- Larger horsepower motors can be grouped with smaller ones

Group Installation under 430-53(c) requires that the BCPD be calculated and either supplied within the control panel or, if mounted externally, the BCPD value must be specified by a label within the panel. Always refer to the NEC code before applying the KT7, KTA3 or KT4 in Group Motor Installations.

As stated earlier, Group Installations have been popular applications for KT7, KTA3 and KT4 Motor Circuit Controllers in North America. They greatly reduce cost when compared to using fuses or circuit breakers in each motor branch circuit.

## Motor Disconnecting Applications - UL/CSA

The KT7 Motor Circuit Controllers are also UL/CSA listed as manual motor controllers with the optional approval "Suitable for use as a motor disconnect." This UL Listing (UL508, Part III) allows KT7s to meet the requirements for applications as "at-motor" disconnects. All manual starters used in such applications must be marked as "Suitable for use as a motor disconnect". The KT7 can be used in an enclosure with a lockable handle as a manual motor starter and is an approved means of motor disconnect.

Under the provisions of UL508 Part III, a Manual Motor Controller can be labeled "Suitable for use as motor disconnect" and does not require compliance with UL 98 Disconnect Rules. The primary difference between UL98 and UL 508 Part III is that the Manual Motor Controller must bear a maximum KAIC rating. This rating must be considered in the application of KT7 as a motor disconnect.

Corresponding to this section of UL, the NEC code Article 430-109 a1b6 [CEC 28-602 (3)(b)] permits the use of a manual motor controller when installed between the BCPD and the motor.

## Self-Protected Manual Combination Starter Applications (Type E) - UL/CSA

Type E Controllers were recognized by UL in 1990. UL508, Part IV, Sections A-E (17th Edition) cover combination motor controllers that also provide a disconnecting means, a controller (load switching means), and overload and short-circuit protection, all incorporated within the same device or assembly. Under these provisions, the KT7 Self-Protected Motor Circuit Controllers, with improved current limiting and breaking capacity (KAIC rating), are now UL/CSA Listed as Construction Type E manual combination motor controllers. This Type E rating eliminates the need for individual branch fuses (per UL 198) or a thermal-magnetic circuit breaker or magnetic-only circuit breaker (per UL 489) as the Branch Circuit Protection Device (BCPD). See Figure 4.

## Methods of Applying KT7 Motor Circuit Controllers

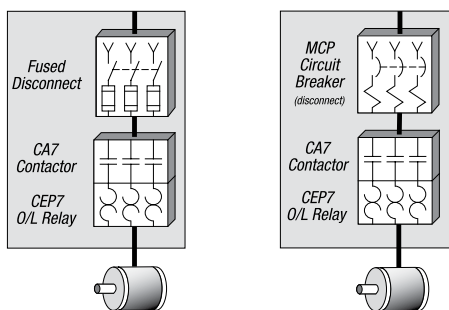

Figure 4  
Classic Combo Starter (NEC Article 430-52)

Further, the Type E rating eliminates the need for an additional disconnecting means (per UL 98) for enclosed and dead-front switches, UL 1087 molded case switches, or UL 489 molded case circuit breakers.

Corresponding to this UL Type E rating, NEC code (Article 430-52 c6) now allows a self-protected combination controller to be used as the BCPD instead of the classic devices listed in Table 430-152 under NEC 430-52c1.

Simply stated this Type E listing allows the KT7 Self-Protected Combination Motor Controllers to be used as short-circuit protection, overload protection, and as the motor disconnect on motor branch circuits. See Figure 5.

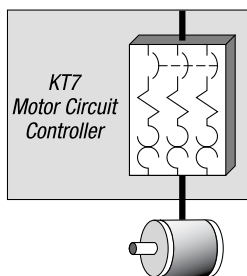

Figure 5  
KT7 Manual Motor Controller and "At motor" Disconnect

It should be noted that the KT7 Manual Motor Circuit Controller, when listed as a self-protected (Type E) device, is rated for Wye-connected power systems for voltages 480Y / 277 volts common in the United States or 600Y / 347 volts common in Canada.

**Effective July 16, 2001** UL made changes to its specifications for self-protected Type E combination controllers. Among them is a required increase in space between line side terminals of a 2 inch creepage distance. This directly affected KT7 controllers in specific applications which is why we introduced the -TE1 adaptors. The adapter

allowed the KT7 to comply with the new requirement for the incoming line.

KT7 controllers used as Branch Circuit Protection Devices (BCPDs) in Type E applications will be required to meet the new specifications. KT7 controllers applied as manual motor starters, or part of a group installation, are exempt from the new requirement.

- All CL7, CK7, enclosed KT7 and CX7 starters assembled with KT7 controllers include the TE1 terminal adaptors.

## Individual Combination Starter Applications

The next logical step is to combine a CA7 contactor to the (Type E) self-protected manual combination KT7 controller. The KT7 starter provides the overload and short circuit protection, as well as, the disconnecting function for the motor, while the CA7 contactor allows for remote operation via push buttons. By contrast, the traditional fusible combination starter consists of a fusible disconnect switch, short-circuit protection (alternately an MCP or MCCB), a contactor for remote operation and a CEP7 overload relay (see Figure 4). The KT7 Type E manual controller + CA7 contactor combination can now be compared with a traditional fusible or circuit breaker Combination Starter including the means of disconnect.

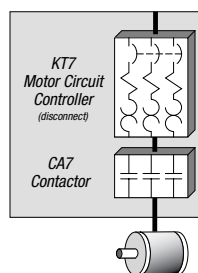

Figure 6  
Type E Combo Motor Controller (starter) and "At motor" Disconnect (NEC Article 430-52 (c6))

## Multi-motor Starter Combination Applications

The KT7 Construction Type E rating also eliminates concern for all of the NEC 430-53 [CEC 28-206] rules for installations involving multiple motor starters in a single control panel. The result is maximum flexibility and minimum panel size without the restrictive and cumbersome rules involved with typical multi-motor (Group Installation) applications.

This means that the main fuses or circuit breaker are no longer necessary to meet the requirement of a Group Installation Branch with Taps.

### Branch Circuit Protection Device (BCPD)

A non-fused disconnect may be needed to meet the safety disconnect rules for the multi-motor starter control panel. It is important to separate the code requirements for BCPD's from the safety codes requiring a panel disconnect to be "in sight and within 50 feet" to protect the maintenance electrician. KT7s perform the function of BCPD's under the Type E combination motor controller approval and may simply be selected according to the motor full-load current with consideration for the potential fault-current.

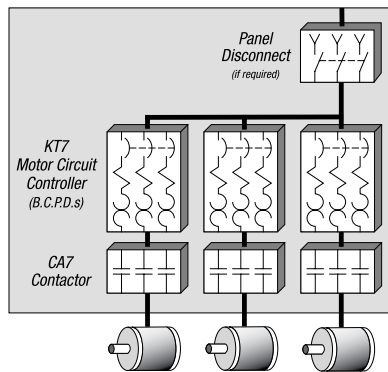

Figure 7

Multi-motor Starter Panel using KT7 as Type E Combo Starter (BCPDs) per NEC Article 430-52 (c6)

## Short-circuit Coordination

UL508 sets safety standards for industrial control equipment. UL standards for starters provide protection against fire or personal injury under fault conditions. Passing a UL short-circuit test means the current carrying parts may not move, which does not imply the device won't be damaged or that the device will be reusable following the fault.

The concept of Type 1 and Type 2 coordination are European based but are certainly not new to the North American market. Fuse companies have been at the forefront of advancing the concepts and advantages of Type 2 protection. An appreciation for the advancements offered by self-protected combination motor controllers like KT7 must start with a firm understanding of standards Type 1 and Type 2 protection versus Construction Type E.

### Type 1

- Under short-circuit conditions, the contactor or starter shall cause no danger to persons or installation.
- Damage to the contactor and the overload relay is acceptable.
- It may not be suitable for further service without repair and replacement of parts.

A UL listing of a device or combination of devices like a contactor and an overload relay would be equivalent to Type 1 coordination in European (IEC) terminology.

### Type 2

- Under short-circuit conditions, the contactor or starter shall cause no danger to persons or installation and shall be suitable for further use.
- The risk of contact welding is recognized, in which case the manufacturer shall indicate the measures to be taken in regards to maintenance of the equipment.

Most of the above is European terminology that has worked its way into North American terminology.

### Type E

Construction Type E Self-protected Combination Motor Controllers

- Do not require branch circuit short circuit protective device (fuse or circuit breaker) upstream
- Includes coordinated overload and short circuit protection
- No welding of contacts is allowed
- Incorporates a motor disconnect rating
- Includes an endurance standard after interrupting a short-circuit exceeding that specified for Type 2.

This means the test for self-protected combination controllers is more stringent than Type 2; therefore, many people refer to Type E with implication not only to the construction type as defined under UL508 and applied in accordance with NEC 430-52C Option 6 but also to the type of coordinated short-circuit protection achieved. More on Type E testing later in this text.

**Short-circuit coordination is about the level of damage allowed to the control equipment under a short circuit condition and the speed of operation is the key to current limitation.**

### Suitability for Tap Conductor Protection

For several years, the industry has been applying manual motor circuit controllers in Group Installations under NEC 430-53C. Many of you have been aware of the vagueness of the current NEC with respect to NEC 430-53D concerning “Single Motor Taps.” The 2002 NEC added a new provision which clarifies the sizing of wires in a Group Installation where the wires feeding each motor circuit controller is considered to be a tap conductor.

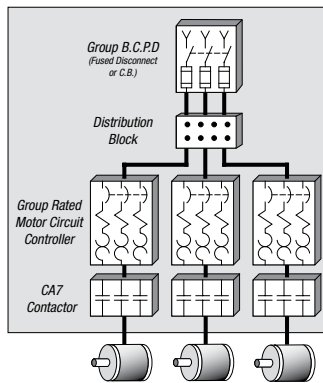

Figure 8  
Article 430-53C Circuitry With  
Group Rated Controller

NEC-430-53-D-1 restricts the wire feeding the motor circuit controller to be equal to the wire connected to the BCPD which is extremely limiting. NEC-430-53-D-2 allows reduction of the sizing of the wire leading to the BCPD to not less than 1/3 of the wire connected to the BCPD. Since most 25 ampere frame motor circuit controllers only allow for #10 wire maximum (which is rated for 40 amperes) per UL508A “Internal Wiring Standard”; it follows that the BCPD must be limited to 120 amperes maximum. Note that the actual FLA connected is limited to 80% of the wire rating. So, applications under NEC 430-53C are directly linked to compliance with NEC 430-53D, with respect to wire sizing on the tap conductors.

The 2002 NEC has provisions for Single Motor Taps under Section 430-53D-3, which clearly provides for sizing motor circuit controller wires at 1/10 if the length does not exceed 10 feet. This means most 25 ampere frame motor circuit controllers that only allow for #10 wire maximum might be as large as 400 amperes (80% rating must apply). Further that 45 ampere frame motor circuit controllers that allow for #4 wire maximum (which is rated for 105 amperes) might be as large as 1050 amperes (80% rating must apply). It should be noted that mini-bus bars, often used to inter-connect

the line side of motor circuit controllers, may increase the capacity of the allowable wire size.

This change in the 2002 NEC does require some additional testing of the motor circuit controller under UL508 in order to mark the device “Suitable for Tap Conductor Protection in a Group Installation.” The testing associated with single motor taps is nearly as difficult as those associated with the test for Self-protected Combination Motor Controllers (described elsewhere in this white paper). This means that the Tap Conductor Protection ratings may well align with the ratings for Self-protected Combination Motor Controllers.

It is the opinion of this writer that the strict enforcement of the wire sizing options defined by NEC 430-53D-1, -2, or -3 will force the industry to apply Self-protected Combination Motor Controllers (Construction Type E or Type F) in multiple motor starter panels under the provisions of NEC 430-52-C-6 as opposed to applying simple Group Rated Manual Motor Circuit Controllers under Group Installations as defined under NEC 430-53-C.

*The most common error on the part of users is to assume that a group rated manual motor controller can be used under the same rule as a self-protected combination motor controller. The two assemblies may look similar but the rules of application are entirely different.*

### Assemblies Using KT7

Since devices like KTA7 do not include a magnetic coil contactor in the assembly, they are considered to be manual motor controllers. If you are building a multi-motor starter panel you probably need to provide for remote control and so you add a contactor to the assembly. Sprecher + Schuh has combined the KT7 Self-protected Combination Controller (Construction Type E) into assemblies with appropriately sized contactors. These assemblies are available in three varieties:

- CL8 = KT7 + Connector + CA8 Mini-contactor
- CL7 = KT7 + Connector + CA7 Contactor
- CK7 = KT7 + CA7 mounted on a DIN adapter socket with terminal blocks

CL8 and CL7 use connectors (i.e: PEK, PEC or PNC type) to mate the KT7 with CA8 and CA7 contactors. Sprecher+Schuh has cUL Approval of our -PEK, -PEC, and -PNC connectors. This means CL8, CL7, and CK7 assemblies have a KAIC rating and are shown on the UL website for SCCR.

## Type E Self-protected Combination Motor Controller Assemblies

An assembly of a Construction Type E KT7 Manual Controller plus a contactor can be tested as a Self-protected Combination Controller. This means the assembly must meet all of the same rigid standards including Type E coordination as described above. Sprecher + Schuh provides additional tables showing the KAIC ratings of CK7 starters approved by UL as Type E assemblies, as well as the CL8 & CL7 ratings that are UL approved for Type E or F respectively.

## Type F Combination Motor Controllers

Manufacturers of Construction Type E controllers have worked closely with UL concerning the addition of a Construction Type F Combination Motor Controller to their specifications and test procedures. UL added Type F to UL508 Part III Section 76. In 2002, Construction Type F was defined as a Type E Manual Self-protected Combination Controller combined with a magnetic contactor but allowing damage to the contactor under a short circuit. The damage allowed to the contactor is similar to that allowed to Construction Type A, B, C or D Combination Starters combined with a standard contactor and overload relay better known as the classic Combo Starters.

A Combination starter (Type A Fusible, or Type B, C or D Circuit Breaker versions) must pass a short-circuit performance test specified by UL508 Table 77.4. Passing a basic short-circuit test means current carrying parts may not move, and there is no requirement for an endurance test following the short-circuit.







Type E Self-Protected Combination starters must not only pass the basic UL short-circuit test, but also pass an endurance test as outlined in UL508 Table 83.1. The test sequence includes make and break two times FLA current, 1000 times at a speed of 1/2 second on and 1/2 second off. The second part of the sequence includes 5000 operations with FLA at a speed of 1 second on and 9 seconds off. The third sequence of these tests requires 4000 operations at no load. No failures are allowed, and that includes no contact welding.

To build a Type F Combination starter you begin with a UL Approved Type E Manual Self-protected Motor controller and add a contactor in an assembly. The assembly is then tested to the same standards you would for a Classic Type A thru D Combination starter (Coordination Type I).

Note that the Type F designation ‘Combination Motor Controller’ is missing the term ‘Self-protected’ which is reserved for an assembly that is fully Type E Approved as described above. This means that Type E assemblies are superior to Type F assemblies with respect to coordinated protection. Both Type F and Type E are valid selections for customers to make an informed price versus performance choice.

Once again, if the customer wants Type 2 protection, the manufacturer must back their recommendations with self-certify testing. Sprecher + Schuh provides additional tables for the customer to select Type 2 KAIC ratings for Type F Combination Motor Controllers in the technical data section of this chapter. It might be said that Construction Type F Coordination Type 2 ratings are very close to those of Type E. It is important to note that the difference is that Type E provides the assurance of an endurance standard after interrupting a short-circuit exceeding that specified for Type 2.

***In short, you could say that Type F1 is good, Type F2 is better and Type E is the best.***

| Construction Type   | Description  |
|---|--|
|  | A Fusible Combination Starter  |
|  | B Short-Circuit Protected Combination Starter  |
|  | C Thermal-Magnetic MCCB Combination Starter  |
|  | D MCP (Magnetic Only) Circuit Breaker Protected Combination Starter  |
|  | E Self-Protected Combination Starter (KTA7)<br>May include KTA7 + CA7 Contactor if the assembly can pass the life endurance test after short-circuit |
|  | F Combination Starter PLUS Magnetic Starter (KTA7 + CA7)   |

### Three Component Starters

We have discussed how a Type E self-protected combination motor controller can be combined with a contactor to be a Type F assembly to meet the requirements of UL508. Further, we have discussed how a self-protected combination motor controller can be combined with a contactor and tested as an assembly to the more stringent Type E standard, resulting in life after a short-circuit for the assembly. We have outlined how our KTA7 is designed for use with standard Design B squirrel cage motors with  $6X \text{ FLA} = \text{LRA}$  start-up current by using a magnetic trip mechanism set for 11-13 X FLA trigger point. We also outlined how our KTC7 is designed for high efficiency Design B or Design E motors with  $9X \text{ FLA} = \text{LRA}$  or higher start-up current by using a magnetic mechanism set for 17-20 X FLA trigger point. Now let's turn our attention to the KTB7 which is a magnetic only device and has no thermal or bimetal overload mechanism.

By definition a Type E/F combination motor controller must provide the following functions:

- Short-circuit protection
- Motor Disconnect
- Controller (Manual unless combined with a contactor)
- Thermal overload protection

This means that a magnetic only motor circuit controller (KTB7) alone can not be a Type E device and if it can not be a Type E device then by definition KTB7 can not simply be combined with a contactor to be a Type F device to protect motors. However, a magnetic only motor circuit controller (KTB7) might be combined with a contactor and a separate overload relay and tested to Type E standards as an assembly. NEC 430-52 C Option 7 states that a magnetic only (instantaneous only) short-circuit protector will be permitted when part of a UL Listed combination motor controller has coordinated motor overload protection and short-circuit in each conductor.

Considering that most applications are well covered with the application of KTA7 or KTC7 Type E or Type F assemblies then one might ask what kind of application would require the 3- component combination of a magnetic only motor circuit controller, a contactor and a separate overload relay. The answer is that some customers have applications that require additional functionality not available with our self-protected combination controllers (KTA7 or KTC7).

These applications might include:

- Multiple motor starter panel requiring individual overload resets
- Class 15, 20 or 30 overload protection rather than Class 10
- Remote control of overload relay reset
- Motor Stall protection
- Ground Fault protection
- PTC thermistor relay functions
- Overload relay communications (Ethernet or Profibus)

Our CEP7 solid state relay can be combined with side-mount protection modules to provide additional protection as specified by the customer for unique applications. The Sprecher + Schuh version of these 3 – component assemblies are called CLT7. Put simply, a CLT7 is another version of a Type E device with additional overload relay features not commonly provide in standard versions.

### A Note About Mini-Circuit Breakers

All too often we see UL1077 DIN rail mounted Mini-circuit breakers applied as branch circuit short-circuit protection ahead of a standard contactor and overload relay. UL1077 Supplemental Circuit Breakers were never intended to replace UL489 Approved Circuit Breakers as short-circuit protection for a motor branch circuit. Some customers might be employing UL1077 circuit breakers to “protect” motor circuits. This product is not approved for this purpose, nor is it in compliance with NEC 430-52.

Sprecher + Schuh sells UL1077 Mini-circuit breakers as well as KT7 Motor Circuit controllers, and it is our desire to help customers apply each in accordance with applicable codes and standards. Please reference our technical application notes in Section M for the proper application of UL1077 Mini-CBs.

There are UL489 Approved Mini-CBs in the marketplace that can be applied on 240 volt and others approved for 480Y/277V motor applications in accordance with UL and NEC. Note that these 240 volt UL489 rated circuit breakers are often seen improperly applied to 480 volt applications. This DOES NOT comply with UL and NEC. KTA7 Motor Circuit Controllers can be applied as motor protection in applications up to 480Y/277 or 600Y/347 volts. There are 480Y/277 volt mini-CB but applying them to motors has additional issues not discussed here.

It should be noted that UL489 Mini-CB's do not comply with UL508 as an overload relay. Therefore anyone applying a UL489 Mini-CB as short-circuit protection must also add a true overload relay to each motor circuit.

Neither UL1077 or UL489 Mini-CBs have the ability to interrupt a high ampere short-circuit with the speed of a KT7 Motor Circuit Controller, nor do they have the KAIC withstand rating, the ability to provide Type 2 coordination and certainly not Construction Type E/F approvals or the same level of equipment protection.

Finally, since KAIC rating of the short-circuit and contactor are required by UL, then SCCR rating must be limited to the 5KA maximum level since these mini circuit breakers have not been tested with the contactor and overload relay as required. For additional information concerning the proper application of UL1077 or UL489 Mini-CB's, please refer to our White Paper located in Section M of the Sprecher + Schuh catalog.

### Methods of Applying KTU7 Molded Case Circuit Breakers

The KTU7 is a UL489 Molded Case Circuit Breaker that provides thermal-magnetic protection for non-motor loads. The KTA7 and KTC7 as discussed in the previous pages can be applied in one of two ways:

- Manual Motor Controller often used in Group Installation per NEC 430-53.C
- Self-Protected Combination Motor Controller (Type E) multiple motor starter applications per NEC 430-52.C.6

A KTA7 applied as a Manual Motor Controller in a Group Installation per NEC 430-53C can be applied to non-motor loads; however, as we have related in the previous pages, Group Installation rules are in declining use. The use of Type E/F rules are taking the lead in applications involving three or more motor starters. Self-protected Combination Motor Controllers are, as the name suggests, for use on motor loads. In multi-motor starter panels there are often other non-motor loads that also require a Branch Circuit Protection Device (BCPD). The purpose of this section of the white paper is to address methods of applying the protecting non-motor loads. Non-motor loads include control circuit transformers, power transformers (1KVA or greater), heaters, blowers, receptacles for portable equipment, refrigeration equipment, and small panels used for power distribution to smaller machines.

In 2011, Sprecher + Schuh conducted a survey of multi-motor starter panel builders. From that survey we determined the common installation practices when assembling a custom control panel involving three or more motor starters and protection methods for non-motor loads. We found that many users prefer a fuse-less system, but our survey indicates fuses are still used by many to protect non-motor loads. Those who use fuses are utilizing Class CC and J-Type fuse blocks and fuses as short-

circuit protection of non-motor loads. It is clear that most customers have switched away from RK1 and RK5 fuses in favor of the faster acting Class CC and J-Type fuses because they limit let-through. Failing to limit let-through current allows damage to downstream equipment. We might assume that fuses are still being utilized in part because of cost but also because fuse companies have historically touted that fuses are faster than molded-case circuit breakers. Further that fuses are current limiting and molded case circuit breakers are not current limiting.

These facts are true in comparison to 600 Volt class molded case circuit breakers, but 480Y/277 volt molded case circuit breakers (like KTU7) are different. During a fault condition the peak current ( $I_p$ ) is reached in  $\frac{1}{4}$  of a cycle (4 ms) which results in mechanical damage to electrical equipment. The  $I^2t$  (area under the curve) represents the heat damage produced by the fault. KTU7 (and KTA7, KTB7 and KTC7) operates in 2 ms (2/1000 second) (reference Section F of current Sprecher + Schuh catalog for time-current curves). Fault curves are parabolic which means the KT7 family of devices reduce the damaging fault curve to much less than one-half as shown in Figure 9.

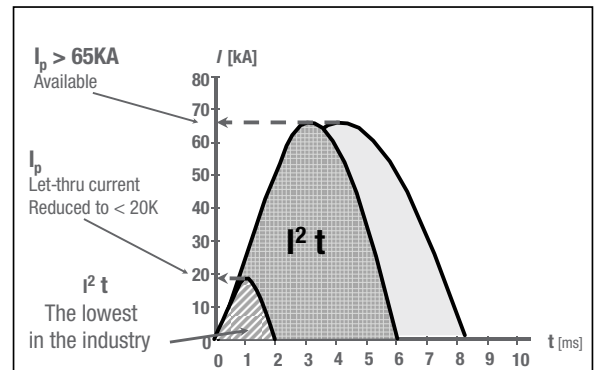

Figure 9 KTU7 Limits  
Let-through Current  $I$  and  
Let-through Energy  $I^2t$

We found from our survey that a percentage of people are using UL1077 Supplemental Protectors for short-circuit protection of non-motor loads. UL1077 Supplemental Protectors are NOT approved for use as the Branch Circuit Short-circuit Protection Devices (BCPD) feeding space heaters, power transformer (1KVA or more), or receptacles. The rules for applying UL1077 circuit breakers as the primary of a control circuit transformer are very limiting and we believe that many may be applied in violation of NEC, CSA and UL standards. The term "Supplemental" is the key as these UL1077 Supplemental Protectors can be used to protect a load that is NOT required (supplemental) by code. i.e.: protect a PLC card from downstream short-circuit in the control circuit.

## Methods of Applying KT7 Motor Circuit Controllers

---

Many customers are currently using 480Y/277 volt UL489 Approved Mini-CB to protect non-motor loads; this application is in accordance with UL, NEC and CSA codes. Most UL489 Mini-CBs are rated only 10 KA. A few UL 489 Mini-CBs in the market place are rated up to 14 KA. A UL489 Mini-Circuit Breaker (like L9) is the most cost effective method of providing a fuse-less system for protecting non-motor loads that is code compliant for 240V and 480Y/277 volt. The disadvantage of UL 489 Mini-CB is that since the SCCR rating of the assembled panel is based on the weakest link, then the 10 KA or 14 KA rating becomes the overall SCCR rating of the panel even if the Self-Protected Combination Motor Circuit Controller (KTA7 or KTC7) protecting the motor loads may be rated 65 KA.

KTA7 and KTC7 and similar competitive devices are not approved as a Type E device for short circuit protection of non-motor loads. Any of our customers using these Type E devices to protect non-motor loads are not in compliance with UL, NEC and CSA codes. The introduction of the UL489 Approved KTU7 Molded Case Circuit breaker provides an alternative for application on non-motor loads including control circuit transformer, power transformers (1 KVA or greater), heaters, blowers, receptacles for portable equipment, refrigeration equipment, and small panels used for power distribution to smaller machines.

The advantages of using a KTU7 Molded Case Circuit Breaker to protect non-motor loads in a multi-motor starter panel are:

- Independent thermal protection under overload condition and magnetic protection under short circuit condition.
- KTU7 distinguishes the difference between an overload and a short circuit, therefore simplifying trouble shooting a problem.
- Cost savings and 50% space savings in comparison to 600 Volt Class UL489 Molded Case Circuit Breaker
- Space savings in comparison to a 480Y/277 Volt UL489 Mini-CB.
- UL489, CSA22.2 No.5 and IEC 9047-2 approval which means the KTU7 is a internationally approved circuit breaker good in North America and European CE applications.
- Available in 2-pole and 3-pole version and has a 100% rating up to 15 amperes and 80% rating (equal to other MCCB) from 16 to 30 amperes.
- KTU7 has a 100KA rating up to 10 amperes at 480Y/277V (50 KA at 600Y/347V) and 65 KA from 12 ampere to 30 amperes continuous at 480Y/277V (53KA at 600Y/3437V).

When combined with KTA7, the SCCR rating for the entire assembly increases to as high as 65 KA at 480Y/277V (47 KA at 600Y/347V). *Please reference specific ratings for your application selection.*

- KTU7 is a current limiting device with a 2 ms trip time which reduces the downstream damage to contactors and other equipment during a short-circuit condition.
- KTU7's not only look similar to the rest of the KT7 family; they can also be connected on the line side with compact bus bars and a feeder supply block resulting in a compact, labor saving, and clean panel design similar to what is available for KTA7.
- Pre-formed connectors for KTU7 to CA7 contactors provide a uniform look to similarly connected KTA7 to CA7 units in a multi-motor starter panel.
- KTU7 can have (2) field installed standard auxiliary contacts or trip indicating auxiliary contacts. Compatible under-voltage and shunt-trip side mount modules will also be available.

We believe the above list represents some significant advantages over previous methods of protecting non-motor loads in a multi-motor starter panel.

### Summary

In summary, a KT7 can be applied as a Manual Motor Controller, Group Installation Overload Relay or a Manual Self-Protected Combination Motor Controller (Type E). CL7, CLT7 and CK7 can be applied as a Self-Protected Combination Motor Controller assembly (Type E or F) based on selection. In addition to the above, the CL8 can be applied as a Combination Motor Controller (Type F).

Fuses or circuit breaker are no longer necessary to meet the requirement of a Group Installation BCPD for motor loads. A label within the panel specifying the BCPD outside the panel is a thing of the past. Multi-motor starter panels using the KT7 verses Sprecher + Schuh's previous Motor Circuit Controller (KTA3) probably won't look much different. The real difference is the NEC rules applied to accomplish the task, along with an increased level of KAIC Type 2 protection against the possibility of a short-circuit fault.

KTU7 UL489 approved Molded Case Circuit breakers offer an alternative to fuses or UL489 Mini-Circuit breakers to protect non-motor loads, resulting in higher SCCR ratings on multi-motor starter panels.

Applying these state-of-the-art controllers properly in North America requires a working knowledge of UL, CSA, and NEC. It is our objective to assist customers in keeping pace with developments that can impact the cost effective protection of their control systems, reduce downtime, and increase production for their customers. We encourage customers to contact their local Sprecher + Schuh representative or the factory to discuss issues about application of these devices.

*This white paper is only a guide. Be sure to consider all applicable local and national codes for your particular installation.*



**Sprecher + Schuh US Division Headquarters**

15910 International Plaza Drive  
Houston, TX 77032

Customer Service: (877) 721-5913

Fax: (800) 739-7370

**Sprecher + Schuh Canadian Deivision**

10 Spy Court  
Markham, ON L3R 5H6

Customer Service: (905) 475-6543

Fax: (905) 475-0027

**[www.sprecherschuh.com](http://www.sprecherschuh.com)**



Series KT7  
Motor Circuit Controller  
*Methods of Applying*

TECH-APPLYINGK7-312 3/12

Sprecher + Schuh has provided reliable control and protection solutions for its customers since 1903.

Today, Sprecher + Schuh offers a wide range of low-voltage industrial control products, including contactors, a variety of relays, starters, push buttons, switches, terminals and controllers, to name a few. All of our products are crafted with precision and tested rigorously for performance — far exceeding industry standards. Moving forward, we continue along the path of constantly seeking innovative ways to provide solutions for our customers. It is by this philosophy that Sprecher + Schuh has come to be the industrial control manufacturer of choice for many customers around the globe seeking quality, reliability, and a name they can trust.