

CA6-115...420 Contact Inspection & Replacement

We are frequently asked how to evaluate the durability of CA6 contacts and when should they be replaced. We are also asked if maintenance will extend the life of the contacts.

Evaluation of contact condition

The contact surface of a new contact system is by no means smooth. It consists of a large number of small surfaces through which the partial currents flow from the fixed contact to the movable contact. The reason for this is the “natural” roughness of the surface of the contact plate, which does not affect the practical function of the contact (Fig. 1).

Distinctly visible traces of erosion are left behind by the very first switchings, and after a larger number of switchings are distributed over the entire contact surface. After a small number of switchings the entire contact surface is rough and blackened. Notched edges and erosion tapering toward the arcing chamber are also normal signs of wear (Fig. 2).

It is particularly important for the contact making to occur exclusively with the silver plating; whether the plating is smooth or eroded is not so important. The end of the contact element service life is reached when larger pieces have broken out of the contact plating, or when the danger of contact with the base material exists (Fig. 3).

Note that contact erosion need not be equal on all three poles. This is because the opening operation is usually synchronized with the AC control phase of the same supply source ❶. The result of this is that the extinguishing phase is always the same. Periodic changing of the control phase will provide a more uniform burn-off of the contact system. The assessment of wear is to be based on the contact element exhibiting the greatest amount of wear.

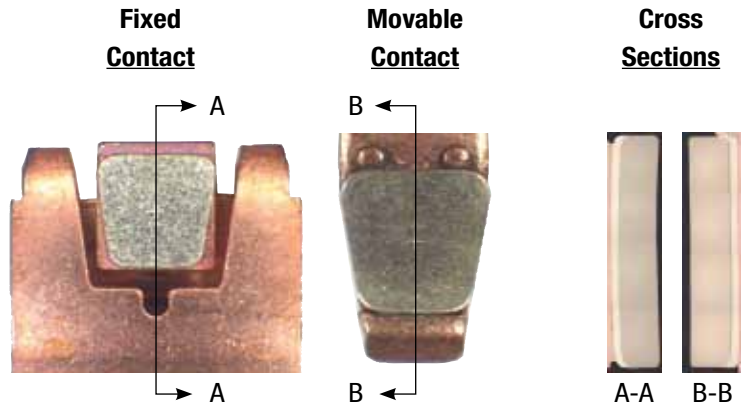

Fig. 1: Contacts in new condition.

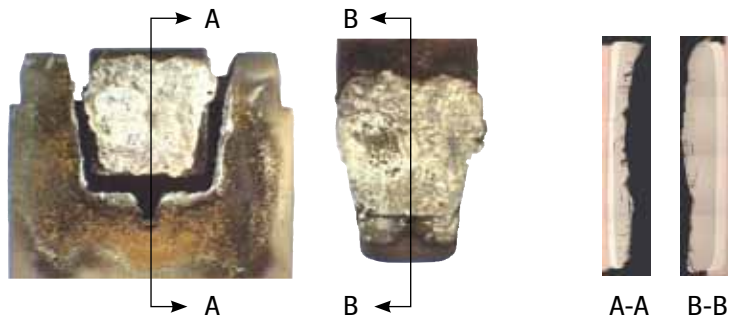

Fig. 2: Contacts after 75% (700,000 operations) of their electrical durability. The contact material is partially eroded, but still usable. ❷

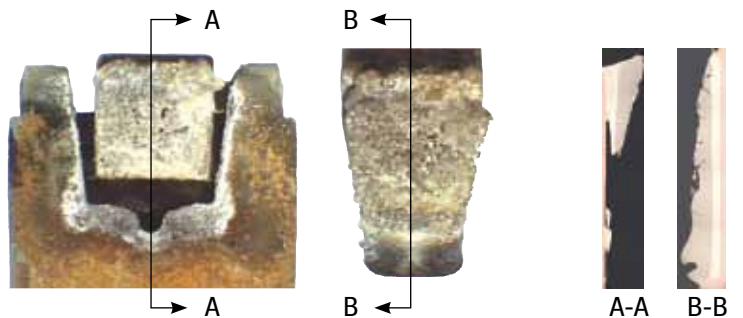
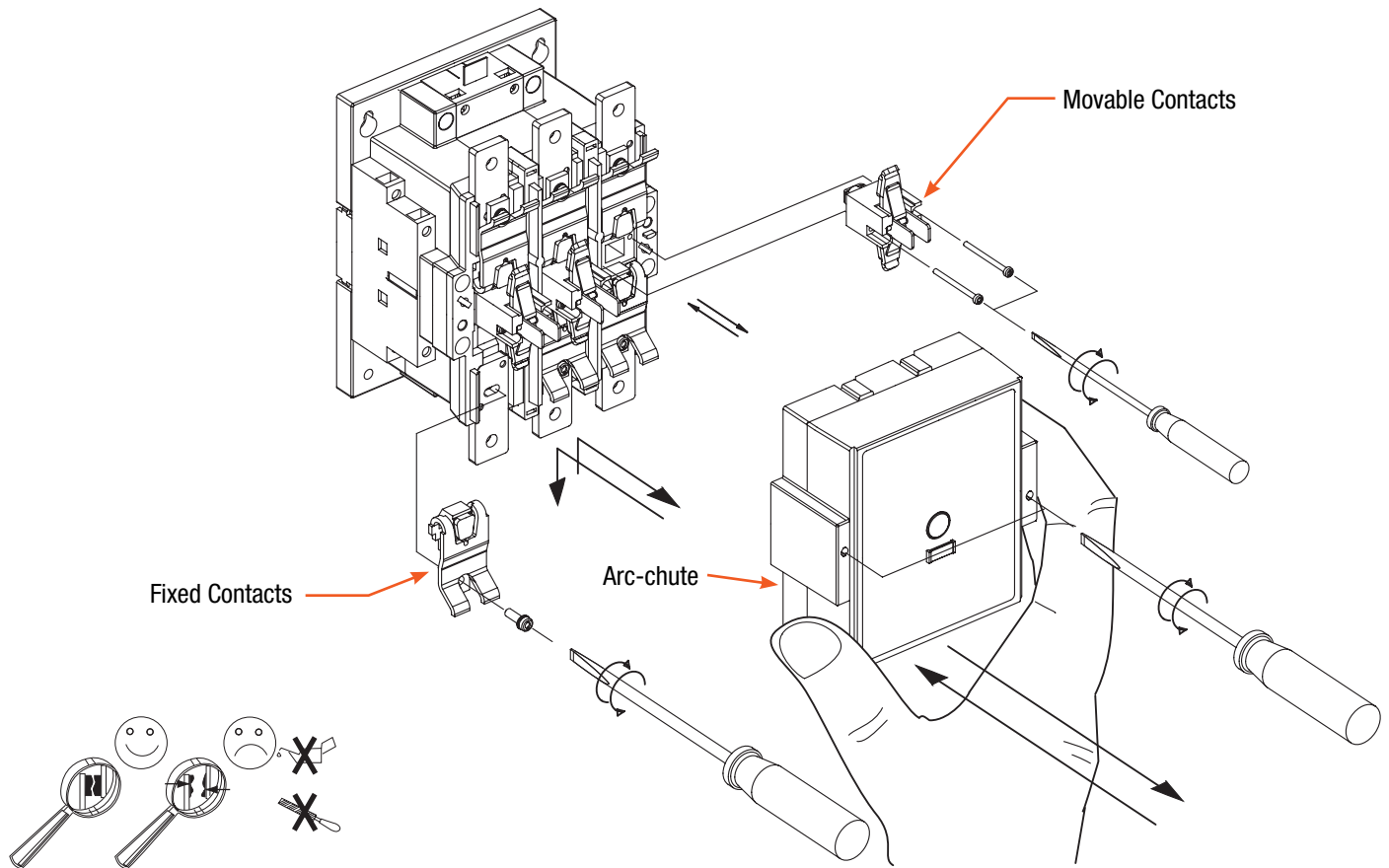

Fig. 3: Contacts at the end of durability (>1 million operations). The carrier material is visible, and the contact material is completely eroded down to the carrier. Further usage will produce unacceptable heating and welding of contacts. ❷

CA6 Contact Inspection & Replacement



Contact maintenance & repair

Silver alloy contact tips retain favorable characteristics with respect to contact reliability, closing capability, and current carrying capacity even with an eroded surface. No lubrication or routine maintenance is required. Under no circumstances should rough contact surfaces be filed smooth because such action will not improve the switching performance and valuable contact material would only be lost.

After a short circuit, the main contacts and arc-chute must be examined. When the coil is energized the arc-chute is mechanically locked. Examination of the contacts can be accomplished quickly by removing the contactor cover after disconnection of power. With the arc-chute removed the contactor is mechanically locked. If the contacts are

welded, the arc-chute can be removed by exerting more force. Slight welds can be separated with a screwdriver.

The fixed and movable contacts can be removed with a screwdriver and compared for surface integrity. If necessary, new contacts can be screwed into place and the cover repositioned. No other examination is required.

Footnotes:

- ① Uniform burn-off of all three phase contacts can be obtained by periodically changing over the phases of the AC control circuit.
- ② The pictures of the contacts are from an AC-3 durability test with a CA6-250-EI-11 208-277VAC. The test conditions were:
 $U_e = 415V$, $I_e = 250A$ (AC-3: Make = $6 \times I_e$, Break = $1 \times I_e$),
 $f = 50Hz$, $\cos \phi = 0.35$, 180 ops/h,
durability reference = 1 Million operations