

# **Intelli-Stop Option Manual**

## **for Series PN Smart Motor Controller**

### **Wiring and Set-Up Procedures 24-1000 Amps**

#### **Manual's Purpose**

This is a supplementary guide for the Intelli-Stop Option and is intended to be used with the Installation Manual. This guide contains the information pertaining to the wiring and customer adjustment set-up procedures for the Intelli-Stop Option. Other information specific to the operation and maintenance of the Series PN is given in the following Installation Manuals:

- TECH-PN24-135 (24, 35, 54, 97, 135 Amps)
- TECH-PN180-360 (180, 240, 360 Amps)

# Intelli-Stop Option

## Application Considerations

The Intelli-Stop function can control loads which have no more than five times motor inertia measured at the motor shaft. Operation is not recommended for loads with greater than five times motor inertia reflected to motor shaft.

For multi-speed, reversing and multi-motor applications, consult your Sales Office.

Figure 1.1 - Intelli-Stop Option Factory Settings

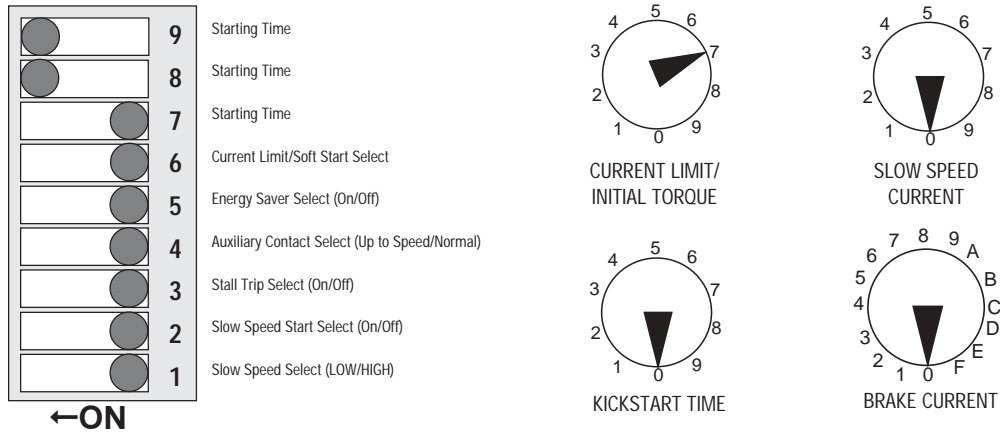

## Factory Settings

The controller has been factory-set for the following as shown in Figure 1.1 above:

- 10 Second Ramp
- Energy Saver “OFF”
- Auxiliary Contacts “OFF” (Normal)
- Stall Feature “OFF”
- Brake Current “OFF”
- Initial Torque 70%
- Kickstart “OFF”
- Slow Speed Start “OFF”
- Slow Speed “HIGH”
- Slow Speed Current “OFF”

**NOTE:** Intelli-Stop feature is deactivated with factory settings.

---

**WARNING:** The Intelli-Stop option is not intended to be used as an emergency stop. Refer to the applicable standards for emergency stop requirements.

---



---

**NOTE:** Depending on the application, the Intelli-Brake, Intelli-Stop and Slow Speed with Braking options may cause some vibration or noise during the stopping cycle and this may be minimized by lowering the braking current. If this is a concern in your application, consult the factory prior to applying these options.

---



---

**CAUTION:** Slow speed running is not intended for continuous operation due to heat produced in the motor and reduced motor cooling. Therefore, select the lowest slow speed current setting that will accelerate and drive the load.

---

This function provides motor braking and preset slow speed. The Intelli-Stop option provides a method to brake a motor from full speed to a slow speed, and to stop for positioning, as show in Figure 1.3. Braking current is adjustable from 150% to 400%. Slow speed current is adjustable from 50% to 450% of full load current. Slow speed can be selected for either 7% (LOW) or 15% (HIGH) operation.

Referring to Figure 1.2 and 1.3, to start the motor press the Start pushbutton and the motor will accelerate to full speed as selected. For stopping the motor, press and hold the Intelli-Stop pushbutton.

The motor will brake to slow speed and operate until the Intelli-Stop pushbutton is released. If the motor does not operate at slow speed, then increase the slow speed current settings. After the Intelli-Stop pushbutton is released, the motor will brake for one second or coast as selected.

Figure 1.2 - Intelli-Stop Terminal Wiring

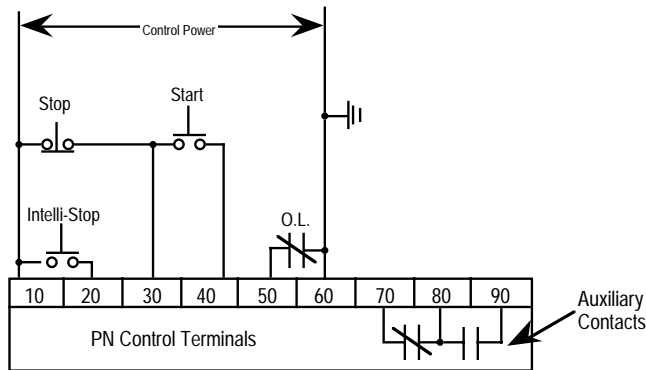
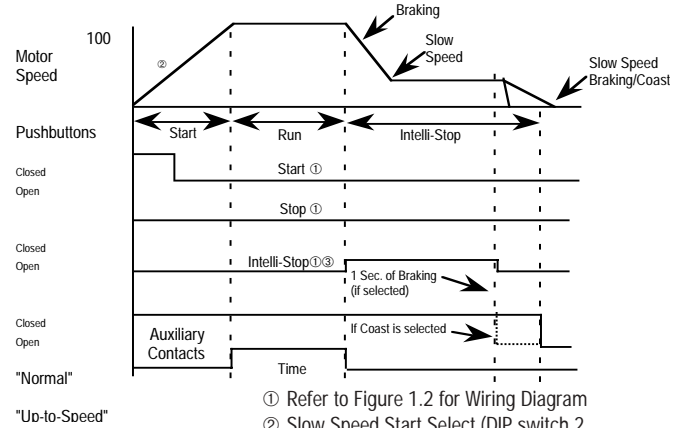

Figure 1.3 - Intelli-Stop Option



- ① Refer to Figure 1.2 for Wiring Diagram
- ② Slow Speed Start Select (DIP switch 2 "OFF")
- ③ When Intelli-Stop pushbutton is closed, start/stop function is disabled

### Intelli-Stop with Slow Speed Start

Referring to Figure 1.2 and 1.4, if the Intelli-Stop pushbutton (Slow Speed) is pressed and held, the motor will operate at slow speed when Slow Speed Start is selected.

To go from slow speed to full speed, press the Start pushbutton and then release the Intelli-Stop (Slow Speed) pushbutton. The operation of Intelli-Stop from full speed to stop is the same as explained on the previous page.

If immediate transition from slow speed start to full speed is not required, release Intelli-Stop (Slow Speed) pushbutton before pushing the Start pushbutton. The motor will coast or brake to rest depending on the Brake Current setting. This is similar to the Preset Slow Speed option.

Figure 1.4 - Intelli-Stop Option with Slow Speed at Start

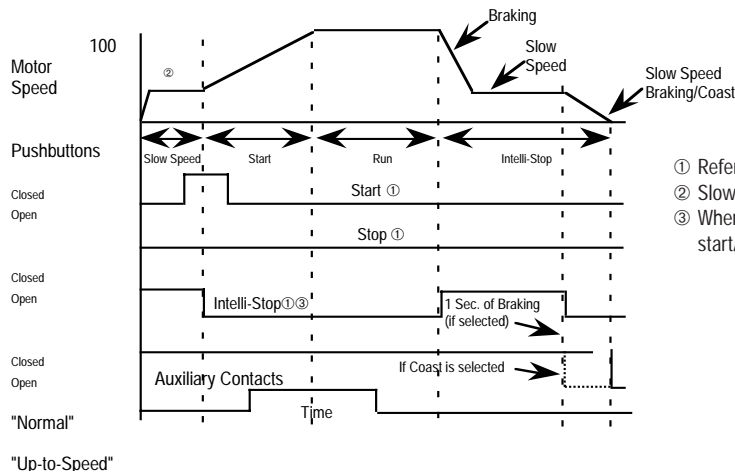

- ① Refer to Figure 1.2 for Wiring Diagram
- ② Slow Speed Start Select "ON"
- ③ When Intelli-Stop pushbutton is closed, start/stop function is disabled

## Soft Start Selection with Intelli-Stop Option

1. **Starting Time** - Set switches 7-9 according to the period desired. For example, if you want a ramp of 20 seconds, switch 7 would be ON and switches 8 and 9 would be OFF.
2. **Kickstart Time** - Set Kickstart Time rotary digital switch to the desired value.
3. **Initial Torque** - Set Initial Torque rotary digital switch to the desired value.
4. **Current Limit/Soft Start** - For soft start operation, switch 6 must be OFF.
5. **Energy Saver Select** - Set switch 5 ON if you want the energy saver feature (or OFF if you do not want this feature active).
6. **Auxiliary Contact Select** - Set switch 4 OFF if you want “normal” auxiliary contacts, ON if you want “up-to-speed” auxiliary contacts.
7. **Stall Select** - Set switch 3 ON if you want the stall feature (or OFF if you do not want this feature active).  
**NOTE:** For resistive load operation, switch 3 must be OFF.
8. **Slow Speed Start Select** - Set switch 2 ON for slow speed at start and OFF for no slow speed at start.
9. **Slow Speed Select** - Set switch 1 for the desired preset slow speed: On for 7% (LOW) and OFF for 15% (HIGH) of base speed.
10. **Slow Speed Current** - Set Slow Speed Current rotary digital switch for preset slow speed current. Adjust until operation is satisfactory. Zero position disables slow speed and braking functions.
11. **Brake Current Select** - Set Brake Current rotary digital switch for the desired performance. Switch settings 0-7 will provide braking current until slow speed is reached. When the Intelli-Stop pushbutton is released (Open), the motor will coast.

Setting 8-F will provide braking current until slow speed is reached. When the Intelli-Stop pushbutton is released (Open), the controller will provide braking current for one second to stop the motor.

**Soft Start Selection with Intelli-Stop Option**  
(continued)

**Figure 1.5 - Set Up Procedures for Soft Start Selection with Intelli-Stop Option**

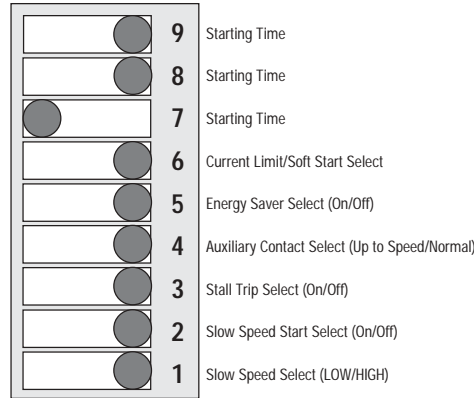

←ON

EXAMPLE: Above DIP switch is set for 20 second ramp.

Switch Number	Time (seconds)					
	2	5	10	20	25	30
9	ON	Off	ON	Off	ON	Off
8	Off	ON	ON	Off	Off	ON
7	Off	Off	Off	ON	ON	ON
6	Off					
5	ENERGY SAVER SELECT					
4	AUXILIARY CONTACT SELECT					
3	STALL SELECT					
2	SLOW SPEED START SELECT					
1	SLOW SPEED SELECT (LOW/HIGH)					

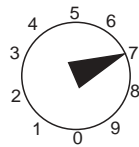

CURRENT LIMIT/  
INITIAL TORQUE

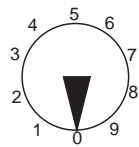

KICKSTART TIME

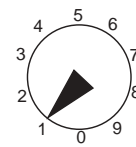

SLOW SPEED  
CURRENT

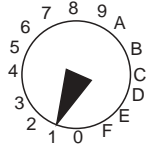

BRAKE CURRENT

EXAMPLE: Slow Speed Current rotary digital switch is set to 50% and Brake Current rotary digital switch is set at 175% with coast from slow speed.

**Kickstart Time**

Position	0	1	2	3	4	5	6	7	8	9
Time (seconds)	Off	.4	.6	.8	1.0	1.2	1.4	1.6	1.8	2.0

**Initial Torque**

Position	0	1	2	3	4	5	6	7	8	9
% of Locked Rotor Torque	5	10	20	30	40	50	60	70	80	90

**Slow Speed Current**

Position	0	1	2	3	4	5	6	7	8	9
% of Full Load Current	Off	50	100	150	200	250	300	350	400	450

**Brake Current - Slow Speed Coast**

Position	0	1	2	3	4	5	6	7
% of Locked Rotor Current	150	170	200	225	250	300	350	400

**Brake Current - Slow Speed Brake**

Position	8	9	A	B	C	D	E	F
% of Locked Rotor Current	150	170	200	225	250	300	350	400

## Current Limit Selection with Intelli-Stop Option

1. **Starting Time** - Set switches 7-9 according to the period desired. For example, if you want current limit active for 30 seconds, switch 9 would be ON and switches 7 and 8 would be OFF.
2. **Kickstart Time** - Set Kickstart Time rotary digital switch to 0.
3. **Current Limit/Soft Start** - Switch 6 must be ON in the current limit mode. Set Current Limit rotary digital switch accordingly. For example, if you want to restrict the starting current to 300% of full load amperes, set rotary switch to position 5.
4. **Energy Saver Select** - Set switch 5 ON if you want the energy saver feature (or OFF if you do not want this feature active).
5. **Auxiliary Contact Select** - Set switch 4 OFF if you want “normal” auxiliary contacts, ON if you want “up-to-speed” auxiliary contacts.
6. **Stall Select** - Set switch 3 ON if you want the stall feature (or OFF if you do not want this feature active).  
**NOTE:** For resistive load operation, switch 3 must be OFF.
7. **Slow Speed Start Select** - Set switch 2 ON for slow speed at start and OFF for no slow speed at start.
8. **Slow Speed Select** - Set switch 1 for the desired preset slow speed: ON for 7% (LOW) and OFF for 15% (HIGH) of base speed.
9. **Slow Speed Current Select** - Set Slow Speed Current rotary digital switch for preset slow speed current. Adjust until operation is satisfactory. Zero position disables slow speed and braking functions.
10. **Brake Current Select** - Set Brake Current rotary digital switch for the desired performance. Switch settings 0-7 will provide braking current until slow speed is reached. When the Intelli-Stop pushbutton is released (Open), the motor will coast.

Setting 8-F will provide braking current until slow speed is reached. When the Intelli-Stop pushbutton is released (Open), the controller will provide braking current for one second to stop the motor.

**Current Limit Selection with Intelli-Stop Option**  
(continued)

**Figure 1.6 - Set Up Procedures for Current Limit Selection with Intelli-Stop Option**

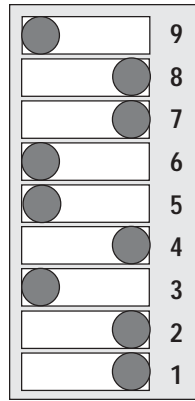

←ON

EXAMPLE: Above DIP switch is set for 30 second current limit.

Switch Number	Time (seconds)	
	15	30
9	Off	ON
8	Off	
7	Off	
6	ON	
5	ENERGY SAVER SELECT	
4	AUXILIARY CONTACT SELECT	
3	STALL SELECT	
2	SLOW SPEED START SELECT	
1	SLOW SPEED SELECT (LOW/HIGH)	

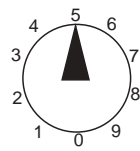

CURRENT LIMIT/  
INITIAL TORQUE

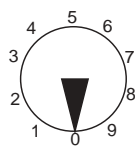

KICKSTART TIME

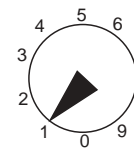

SLOW SPEED  
CURRENT

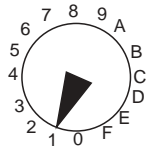

BRAKE CURRENT

EXAMPLE: Slow Speed Current rotary digital switch is set to 50% and Brake Current rotary digital switch is set at 175% with coast from slow speed.

**Kickstart Time**

Position	0	1	2	3	4	5	6	7	8	9
Time (seconds)	Off	.4	.6	.8	1.0	1.2	1.4	1.6	1.8	2.0

**Current Limit**

Position	0	1	2	3	4	5	6	7	8	9
% of Full Load Current	50	100	150	200	250	300	350	400	450	500

**Slow Speed Current**

Position	0	1	2	3	4	5	6	7	8	9
% of Full Load Current	Off	50	100	150	200	250	300	350	400	450

**Brake Current - Slow Speed Coast**

Position	0	1	2	3	4	5	6	7
% of Locked Rotor Current	150	170	200	225	250	300	350	400

**Brake Current - Slow Speed Brake**

Position	8	9	A	B	C	D	E	F
% of Locked Rotor Current	150	170	200	225	250	300	350	400

## Full Voltage Selection with Intelli-Stop Option

1. **Starting Time** - Set switches 7-9 OFF and switch 6 OFF.
2. **Kickstart Time** - Set Kickstart Time rotary digital switch to OFF.
3. **Initial Torque** - Set Initial Torque rotary digital switch to 9.
4. **Current Limit/Soft Start** - For full voltage operation, switch 6 must be OFF.
5. **Energy Saver Select** - Switch 5 must be OFF. Energy Saver is not available with full voltage start.
6. **Auxiliary Contact Select** - Set switch 4 OFF if you want “normal” auxiliary contacts, ON if you want “up-to-speed” auxiliary contacts.
7. **Stall Select** - Set switch 3 ON if you want the stall feature (or OFF if you do not want this feature active).  
**NOTE:** For resistive load operation, switch 3 must be OFF.
8. **Slow Speed Start Select** - Set switch 2 ON for slow speed at start and OFF for no slow speed at start.
9. **Brake Current Select** - Set Brake Current rotary digital switch for the desired performance. Switch settings 0-7 will provide braking current until slow speed is reached. When the Intelli-Stop pushbutton is released (Open), the motor will coast.

Setting 8-F will provide braking current until slow speed is reached. When the Intelli-Stop pushbutton is released (Open), the controller will provide braking current for one second to stop the motor.

**Full Voltage Selection with Intelli-Stop Option**  
(continued)f

**Figure 1.7 - Set Up Procedures for Full Voltage Selection with Intelli-Stop Option**

	9	Starting Time	Time (seconds)
	8	Starting Time	
	7	Starting Time	1/4
	6	Current Limit/Soft Start Select	Off
	5	Energy Saver Select (On/Off)	Off
	4	Auxiliary Contact Select (Up to Speed/Normal)	Off
	3	Stall Trip Select (On/Off)	ENERGY SAVER SELECT
	2	Slow Speed Start Select (On/Off)	AUXILIARY CONTACT SELECT
	1	Slow Speed Select (LOW/HIGH)	STALL SELECT
			SLOW SPEED START SELECT
			SLOW SPEED SELECT (LOW/HIGH)

←ON

EXAMPLE: Above DIP switch is set for full voltage start.

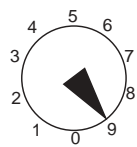

CURRENT LIMIT/  
INITIAL TORQUE

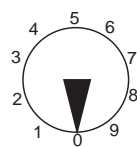

KICKSTART TIME

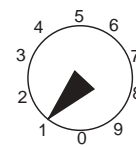

SLOW SPEED  
CURRENT

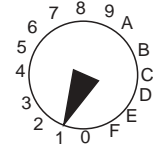

BRAKE CURRENT

EXAMPLE: Slow Speed Current rotary digital switch is set to 50% and Brake Current rotary digital switch is set at 175% with coast from slow speed.

**Kickstart Time**

Position	0	1	2	3	4	5	6	7	8	9
Time (seconds)	Off	.4	.6	.8	1.0	1.2	1.4	1.6	1.8	2.0

**Initial Torque**

Position	0	1	2	3	4	5	6	7	8	9
% of Full Load Current	5	10	20	30	40	50	60	70	80	90

**Slow Speed Current**

Position	0	1	2	3	4	5	6	7	8	9
% of Full Load Current	Off	50	100	150	200	250	300	350	400	450

**Brake Current - Slow Speed Coast**

Position	0	1	2	3	4	5	6	7
% of Locked Rotor Current	150	170	200	225	250	300	350	400

**Brake Current - Slow Speed Brake**

Position	8	9	A	B	C	D	E	F
% of Locked Rotor Current	150	170	200	225	250	300	350	400

## Typical Connection for Retrofit Application

Figure 1.8 shows the typical diagram to use when retrofitting a Series PN with the Intelli-Stop option into an existing control scheme. Starting and stopping of the motor is handled by the controller. Be sure the incoming side of the starter coil is routed through terminals 80 and 90 to insure the starter stays on long enough to allow stopping to occur and that the auxiliary is configured for normal operation.

Figure 1.8 - Typical Connection Diagram Retrofit Application

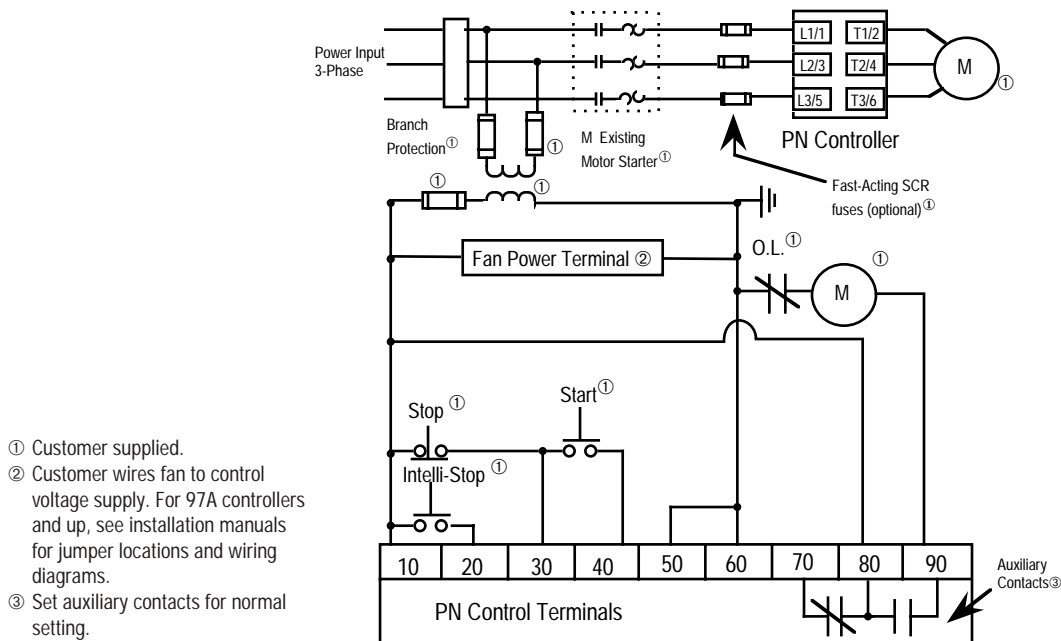

## Typical Connection with Isolation Contactor

Typical connection diagram for Intelli-Stop option with isolation contactor: Both starting and stopping of the motor is controlled by the controller. The controller also controls the electromechanical contactor. The contactor provides isolation between the motor and power lines when controller is OFF.

Figure 1.9 - Typical Connection Diagram with Isolation Contactor

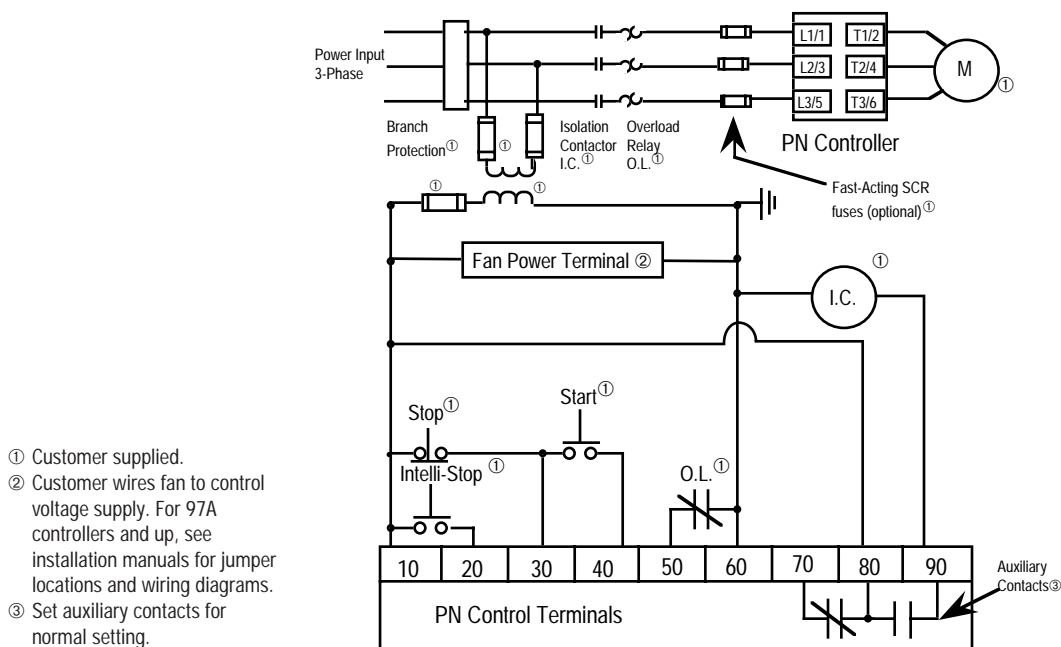

## Programmable Controller and Sensor Interface

When using solid state devices to operate the Series PN controller the voltage and frequency range will be 100-240V, 50/60Hz. The OFF state leakage current from the solid state device must be less than 6mA. The nominal input current is 25mA at 120VAC and 50mA at 240VAC.

Figure 1.10 - Typical Connection with PLC or other Logic Device

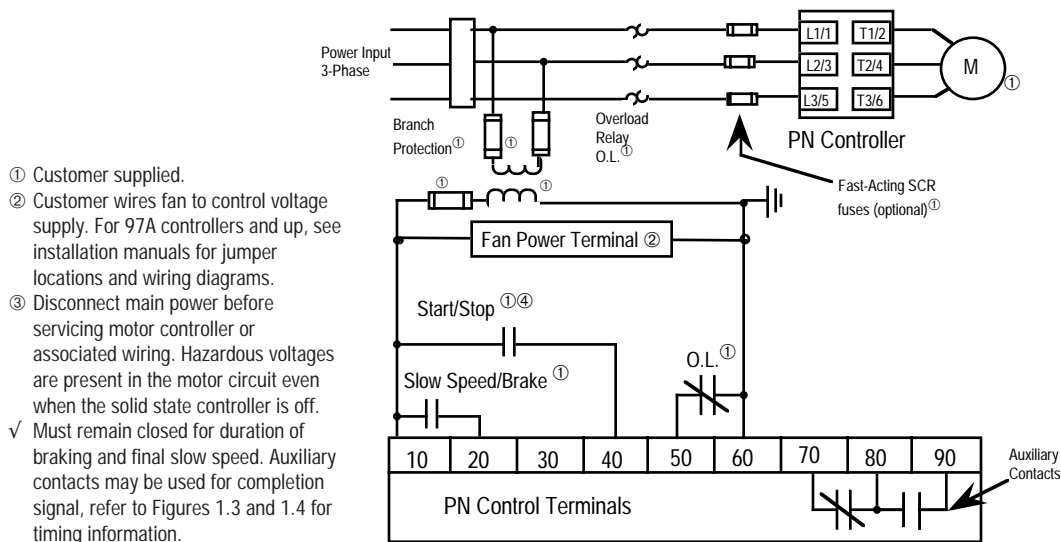

# sprecher+ schuh

## **Divisional Headquarters**

Sprecher+Schuh US Division Headquarters  
15910 International Plaza Dr., Houston, TX 77032  
Tel: (281) 442-9000 Fax: (800) 739-7370  
[www.ssusa.cc](http://www.ssusa.cc)

Sprecher+Schuh Canadian Division  
3610 Nashua Dr., Unit 10, Mississauga, Ontario LV4 1L2  
Tel: (905) 677-7514 Fax: (905) 677-7663  
[www.sscdn.cc](http://www.sscdn.cc)