

Attention: Disconnect from power source before installing or servicing.

Achtung: Vor Installations- oder Servicearbeiten Stromversorgung unterbrechen.

Attention: Avant le montage et la mise en service, couper l'alimentation secteur.

Atención: Desconectar la alimentación eléctrica antes de realizar el montaje y la puesta en servicio.

Attenzione: Togliere tensione prima dell'installazione o manutenzione.

Schachtel 21.381.901-41
Druckvorlage 21.038.948/4.99/Ausg. 2

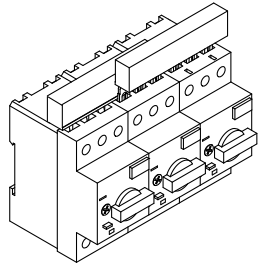

Attention: Disconnect from power source before installing or servicing.

Achtung: Vor Installations- oder Servicearbeiten Stromversorgung unterbrechen.

Attention: Avant le montage et la mise en service, couper l'alimentation secteur.

Attenzione: Togliere tensione prima dell'installazione o manutenzione.

Schachtel 21.381.901-02
Druckvorlage 21.038.941/4.99/Ausg. 2

Atención: Desconectar la alimentación eléctrica antes de realizar el montaje y la puesta en servicio.



Attention: Disconnect from power source before installing or servicing.

Achtung: Vor Installations- oder Servicearbeiten Stromversorgung unterbrechen.

Attention: Avant le montage et la mise en service, couper l'alimentation secteur.

Schachtel 21.381.901-03
Druckvorlage 21.038.944/4.99/Ausg. 2

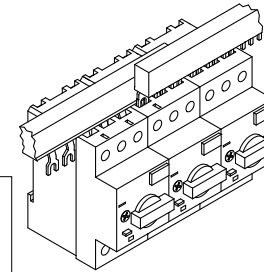

Attenzione: Togliere tensione prima dell'installazione o manutenzione.

Atención: Desconectar la alimentación eléctrica antes de realizar el montaje y la puesta en servicio.



Attention: Disconnect from power source before installing or servicing.

Achtung: Vor Installations- oder Servicearbeiten Stromversorgung unterbrechen.

Attention: Avant le montage et la mise en service, couper l'alimentation secteur.

Schachtel 21.381.901-04
Druckvorlage 21.038.955/4.99/Ausg. 2

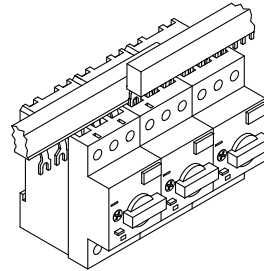

Attenzione: Togliere tensione prima dell'installazione o manutenzione.

Atención: Desconectar la alimentación eléctrica antes de realizar el montaje y la puesta en servicio.



Attention: Disconnect from power source before installing or servicing.

Achtung: Vor Installations- oder Servicearbeiten Stromversorgung unterbrechen.



Attention: Avant le montage et la mise en service, couper l'alimentation secteur.

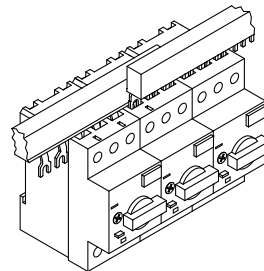

Schachtel 21.381.901-05
Druckvorlage 21.038.958/4.99/Ausg. 2



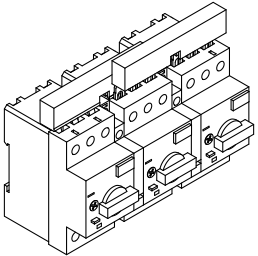

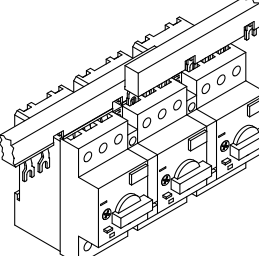

Attenzione: Togliere tensione prima dell'installazione o manutenzione.

Atención: Desconectar la alimentación eléctrica antes de realizar el montaje y la puesta en servicio.

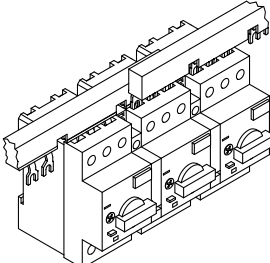
		<p>Attention: Disconnect from power source before installing or servicing.</p> <p>Achtung: Vor Installations- oder Servicearbeiten Stromversorgung unterbrechen.</p> <p>Attention: Avant le montage et la mise en service, couper l'alimentation secteur.</p> <p>Attenzione: Togliere tensione prima dell'installazione o manutenzione.</p>
<p>Schachtel 21.381.901-12 Druckvorlage 21.038.942/5.99/Ausg. 2</p>		<p>Atención: Desconectar la alimentación eléctrica antes de realizar el montaje y la puesta en servicio.</p>

				 <p>Attenzione: Togliere tensione prima dell'installazione o manutenzione.</p> <p>Atención: Desconectar la alimentación eléctrica antes de realizar el montaje y la puesta en servicio.</p>
<p>Schachtel 21.381.901-13 Druckvorlage 21.038.945/5.99/Ausg. 2</p>				

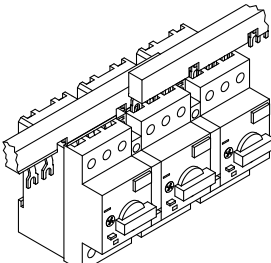
 <p>Attention: Disconnect from power source before installing or servicing.</p> <p>Achtung: Vor Installations- oder Servicearbeiten Stromversorgung unterbrechen.</p> <p>Attention: Avant le montage et la mise en service, couper l'alimentation secteur.</p>				 <p>Attenzione: Togliere tensione prima dell'installazione o manutenzione.</p> <p>Atención: Desconectar la alimentación eléctrica antes de realizar el montaje y la puesta en servicio.</p>
<p>Schachtel 21.381.901-14 Druckvorlage 21.038.956/5.99/Ausg. 2</p>				

 <p>Attention: Disconnect from power source before installing or servicing.</p> <p>Achtung: Vor Installations- oder Servicearbeiten Stromversorgung unterbrechen.</p> <p>Attention: Avant le montage et la mise en service, couper l'alimentation secteur.</p>				 <p>Attenzione: Togliere tensione prima dell'installazione o manutenzione.</p> <p>Atención: Desconectar la alimentación eléctrica antes de realizar el montaje y la puesta en servicio.</p>
<p>Schachtel 21.381.901-15 Druckvorlage 21.038.959/5.99/Ausg. 2</p>				

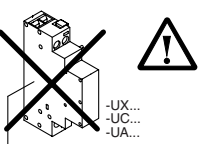
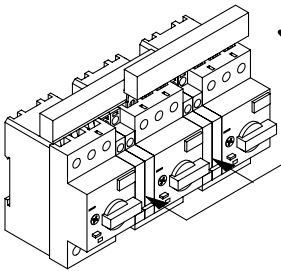

Attention: Disconnect from power source before installing or servicing.

Achtung: Vor Installations- oder Servicearbeiten Stromversorgung unterbrechen.

Attention: Avant le montage et la mise en service, couper l'alimentation secteur.

Attenzione: Togliere tensione prima dell'installazione o manutenzione.

Schachtel 21.381.901-22
Druckvorlage 21.038.943/4.99/Ausg. 3

Atención: Desconectar la alimentación eléctrica antes de realizar el montaje y la puesta en servicio.



Attention: Disconnect from power source before installing or servicing.

Achtung: Vor Installations- oder Servicearbeiten Stromversorgung unterbrechen.

Attention: Avant le montage et la mise en service, couper l'alimentation secteur.

Schachtel 21.381.901-23
Druckvorlage 21.038.946/4.99/Ausg. 3

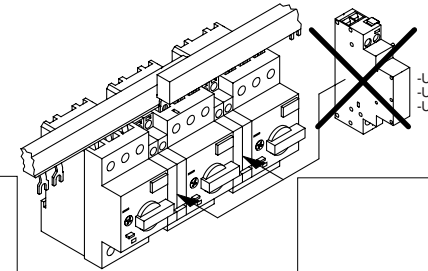

Attenzione: Togliere tensione prima dell'installazione o manutenzione.

Atención: Desconectar la alimentación eléctrica antes de realizar el montaje y la puesta en servicio.



Attention: Disconnect from power source before installing or servicing.

Achtung: Vor Installations- oder Servicearbeiten Stromversorgung unterbrechen.

Attention: Avant le montage et la mise en service, couper l'alimentation secteur.

Schachtel 21.381.901-24
Druckvorlage 21.038.957/4.99/Ausg. 3

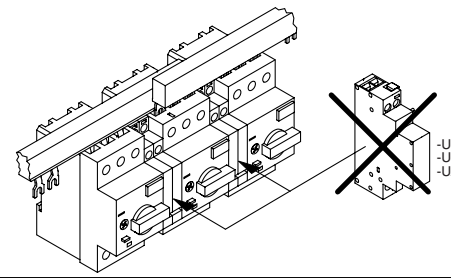

Attenzione: Togliere tensione prima dell'installazione o manutenzione.

Atención: Desconectar la alimentación eléctrica antes de realizar el montaje y la puesta en servicio.



Attention: Disconnect from power source before installing or servicing.

Achtung: Vor Installations- oder Servicearbeiten Stromversorgung unterbrechen.

Attention: Avant le montage et la mise en service, couper l'alimentation secteur.

Schachtel 21.381.901-25
Druckvorlage 21.038.960/4.99/Ausg. 3

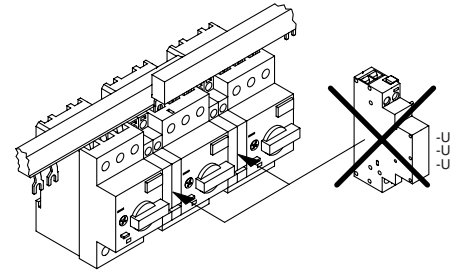

Attenzione: Togliere tensione prima dell'installazione o manutenzione.

Atención: Desconectar la alimentación eléctrica antes de realizar el montaje y la puesta en servicio.

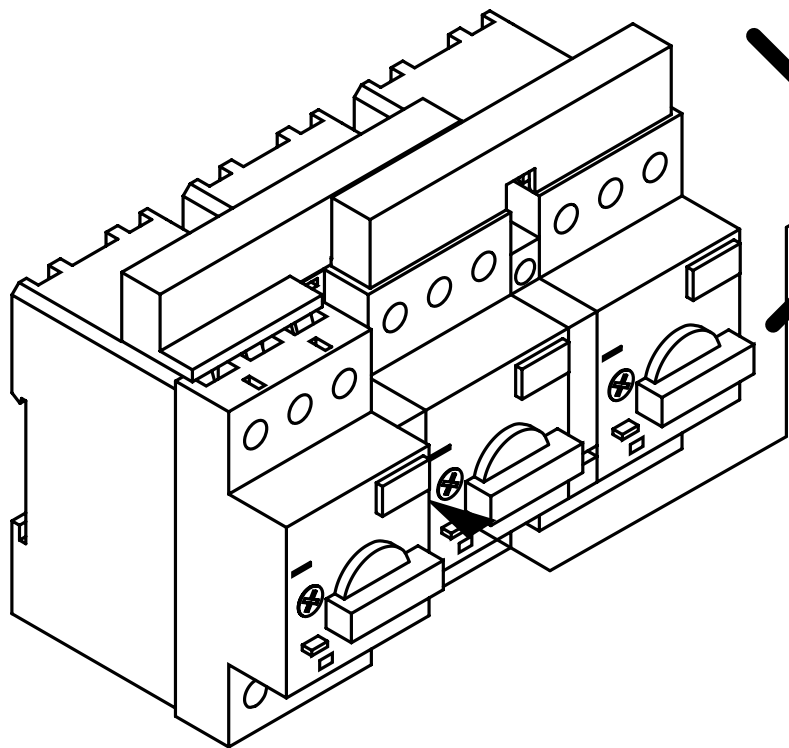

-ASA...
-ASAR...
-PA...
-PAF...



Attention: Disconnect from power source before installing or servicing.

Achtung: Vor Installations- oder Servicearbeiten Stromversorgung unterbrechen.

Schachtel 21.381.901-51
Druckvorlage 21.038.949/4.99/Ausg. 2

Attention: Avant le montage et la mise en service, couper l'alimentation secteur.

Attenzione: Togliere tensione prima dell'installazione o manutenzione.

Atención: Desconectar la alimentación eléctrica antes de realizar el montaje y la puesta en servicio.