

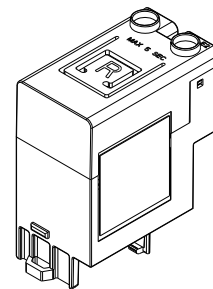

**Overload Relay Remote Reset**  
**Réarmement à distance pour relais thermique**  
**Dezentrales Rücksetzen des Motorschutzrelais**  
**Reset remoto del relé de sobrecarga**  
**Reset remoto do relé de sobrecarga**  
**Relé di sovraccarico con ripristino a distanza**



過電流継電器リモートリセット

过载继电器远程复位

(Cat CMR7N-)

	<b>WARNING</b>	To prevent electrical shock, disconnect from power source before installing or servicing. Install in suitable enclosure. Keep free from contaminants. (Follow NFPA70E requirements)
	<b>AVERTISSEMENT</b>	Avant le montage et la mise en service, couper l'alimentation secteur pour éviter toute décharge. Prévoir une mise en coffret ou armoire appropriée. Protéger le produit contre les environnements agressifs. (Vous devez respecter la norme NFPA70E).
	<b>WARNUNG</b>	Vor Installations- oder Servicearbeiten Stromversorgung zur Vermeidung von elektrischen Unfällen trennen. Die Geräte müssen in einem passenden Gehäuse eingebaut und gegen Verschmutzung geschützt werden. (Befolgen Sie die Anforderungen nach NFPA70E).
	<b>AVVERTENZA</b>	Disconectese de la corriente eléctrica, antes de la instalación o del servicio, a fin de impedir sacudidas eléctricas. Instálelo en una caja apropiada. Manténgalo libre de contaminantes. (Cumpla con los requisitos NFPA70E)
	<b>ATENÇÃO</b>	Para evitar choques, desconectar da corrente elétrica antes de fazer a instalação ou a manutenção. Instalar em caixa apropriada. Manter livre de contaminantes. (Cumpra as exigências da norma NFPA70E)
	<b>ADVERTENCIA</b>	Per prevenire infortuni, togliere tensione prima dell'installazione o manutenzione. Installare in custodia idonea. Tenere lontano da contaminanti. (Seguire i requisiti NFPA70E)
	警告	感電事故防止のため、取付けまたは修理の際は電源から取り外してください。適切なケース内に取付けてください。また、汚染物質がないことを確認してください。(NFPA70Eの要件に従ってください)
	警告	为了防止触电，在安装或维修之前必须先切断电源。安装在合适的设备箱内。防止接触污染物。(符合NFPA70E要求)

	<b>WARNING</b>	Maximum continuous on-time from cold start - 5 seconds. Intermittent duty cycle - 20%.
	<b>AVERTISSEMENT</b>	Temps maximum en fonctionnement continu avec démarrage à froid - 5 seconde. Cycleintermittent - 20%.
	<b>WARNUNG</b>	Maximale kontinuierliche Einschaltzeit vom Kaltstart - 5 Sekunden. Auslösezyklus - 20%.
	<b>AVVERTENZA</b>	Tiempo continuo máximo desde arranque en frío - 5 segundos. Ciclo intermitente efectivo - 20%.
	<b>ATENÇÃO</b>	Tempo máximo de funcionamento contínuo desde a partida a frio - 5 segundos. Ciclo de trabalho intermitente - 20%
	<b>ADVERTENCIA</b>	Tempo massimo di lavaro continuo dall'avviamento a freddo - 5 secondi. Ciclo di lavarointermittente - 20%
	警告	注意: コールドスタートから継続動作までの最大時間 - 5秒。断続使用サイクル - 20%。
	警告	注意: 冷启动后最长连续运行时间为5秒钟。间断占空比20%。

Installation  
Instalación  
Instalação  
Installazione  
取付け方法  
安装

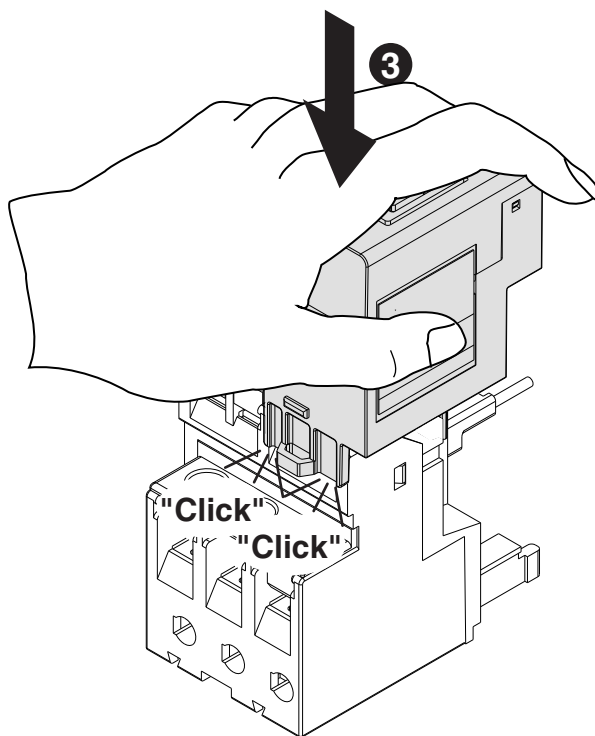
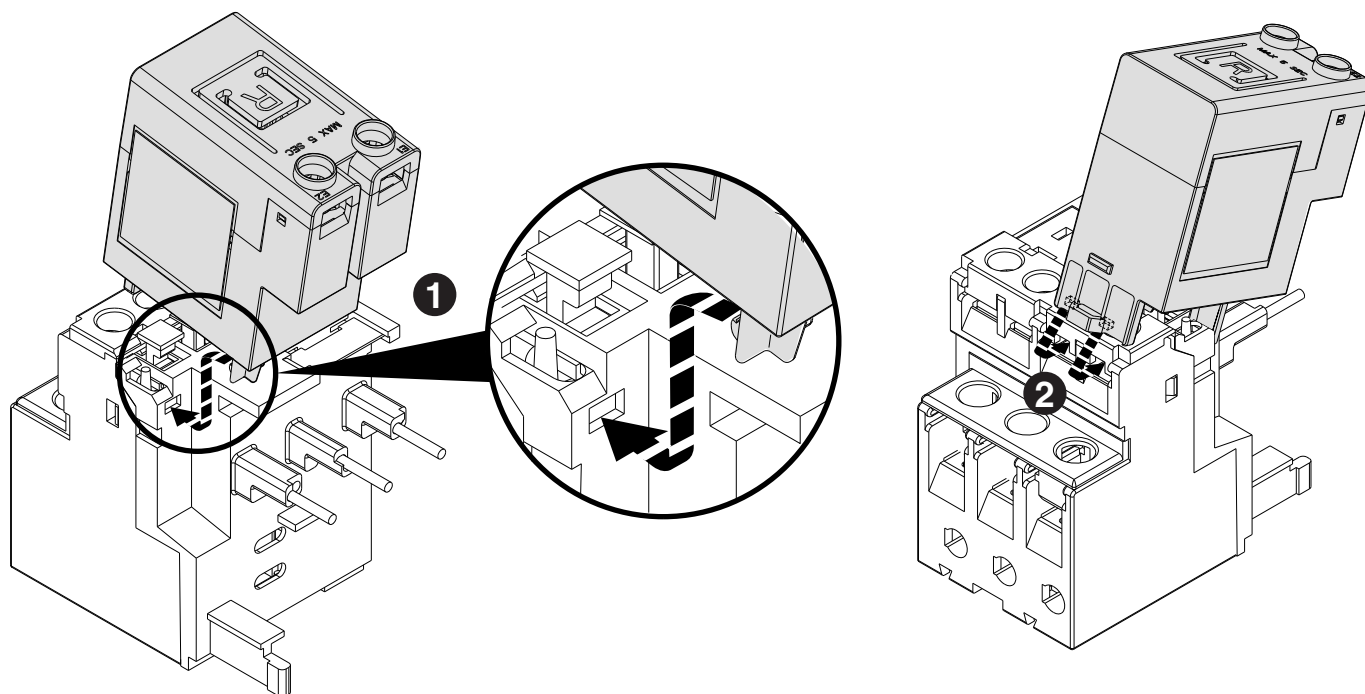

**Removal**  
**Dépose**  
**Ausbau**  
**Rimozione**  
**Remoção**  
**Extracción**  
 取り外し  
 删除

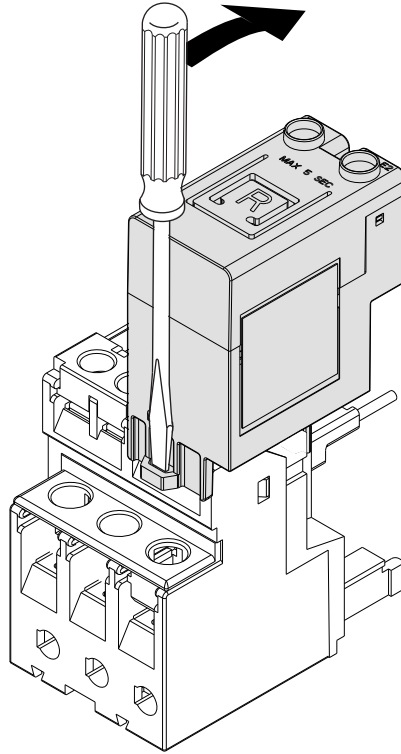

**Main Connections**  
**Bornes de Raccordement**  
**Hauptanschlüsse**  
**Collegamenti Principale**  
**Conexões principais**  
**Conexiones Principales**  
 主体连接  
 主接続

	1X	#16 - #12 AWG 10.6 lb-in
	1X	#16 - #12 AWG 10.6 lb-in
	1X	1 - 2.5 mm <sup>2</sup> 1.2 Nm
	1X	1 - 2.5 mm <sup>2</sup> 1.2 Nm

