



ATTENTION: To avoid shock hazard, remove all power before making adjustments.

DESCRIPTION

The PB Softstarter is designed for low horsepower squirrel cage induction motors. It is intended to relieve the starting torque surge encountered in typical across-the-line starting. This will allow for smoother starts and decrease equipment downtime due to shock and vibration related problems.

ELECTRICAL RATINGS

MOTOR VOLTAGE	CATALOG NUMBER	1 PHASE		3 PHASE		CURRENT RATING
		MAX. HP	MAX kW	MAX. HP	MAX kW	
110VAC 50Hz	PBS-011-120V	-	.75	-	-	11
	PBS-016-120V	-	1.1	-	-	16
	PBS-022-120V	-	1.5	-	-	22
115VAC 60Hz	PBS-011-120V	.5	-	1.5	-	11
	PBS-016-120V	1	-	2	-	16
	PBS-022-120V	1.5	-	3	-	22
200VAC 60Hz	PBS-011-240V	-	-	3	-	11
	PBS-016-240V	-	-	3	-	16
	PBS-022-240V	-	-	5	-	22
230VAC 50/60Hz	PBS-011-240V	1.5	1.5	3	2.2	11
	PBS-016-240V	2	2.2	5	4	16
	PBS-022-240V	3	3	7.5	5.5	22
400VAC 50Hz	PBS-011-480V	-	-	-	4	11
	PBS-016-480V	-	-	-	7.5	16
	PBS-022-480V	-	-	-	11	22
480VAC 60Hz	PBS-011-480V	-	-	7.5	-	11
	PBS-016-480V	-	-	10	-	16
	PBS-022-480V	-	-	15	-	22
500VAC 50Hz	PBS-011-600V	-	-	-	5.5	11
	PBS-016-600V	-	-	-	7.5	16
	PBS-022-600V	-	-	-	11	22
575VAC 60Hz	PBS-011-600V	-	-	10	-	11
	PBS-016-600V	-	-	10	-	16
	PBS-022-600V	-	-	20	-	22

INSTALLATION AND WIRING

Inspection - Before installing the controller, make a complete visual check of the controller for damage in shipment or handling. Claims for damage or missing parts must be made to the carrier as soon as possible after receipt of shipment.

Mounting - The controller is shipped as an open device. No special mounting plate or cooling requirement restrictions are necessary. The operating temperature of the controller is 0 °C to 50 °C.

The open-style controller can be installed in an enclosure. The internal temperature of the enclosure must be kept within the range of 0 °C to 50 °C. Minimum enclosure size for mounting 11 and 16 amp rated devices is 8.5"H X 5.5"W X 6"D.

The minimum enclosure size for mounting the 22 amp device is 11.4"H X 7.4"W X 6"D.

Wiring - The "PB" is to be line powered, no separate control power connections are required. The controller wiring terminal locations are shown in figures 4 & 5. Make wiring connections as indicated in the connection diagrams shown in figures 1, 2 & 3. 3 Phase: Connect the line to terminals L1, L2, and L3. Connect the load to terminals T1, T2, and T3. Single Phase: Connect the line to terminals L1 & L2. Connect the load to terminals T1 & T2.



ATTENTION: The PB controller is required to be connected after an electromechanical motor starter. Refer to the connection diagram Figures 1 - 3.

ADJUSTMENTS

There are two (2) adjustments which will adjust the motor starting characteristics. Use a small screwdriver to pry open access door.

INITIAL TORQUE LEVEL (NOMINAL)

POSITION	0	1	2	3	4	5	6	7	8	9
% OF LOCKED ROTOR TORQUE	10	15	20	25	30	40	50	60	70	80

VOLTAGE RAMP TIME (NOMINAL)
(WITH INITIAL TORQUE SET AT 0)

POSITION	0	1	2	3	4	5	6	7	8	9
TIME (SECONDS)	0.1	0.5	1.0	1.5	2.0	2.5	3.0	3.5	4.0	4.5

- Initial Torque** - The amount of torque developed by the motor when started. The initial torque is adjustable from approximately 10% to 80% of locked rotor torque.
- Time** - The motor voltage gradually increases during the voltage ramp period, which can be adjusted from approximately 0.1 to 4.5 seconds. The higher the "Initial Torque" setting, the shorter the voltage ramp time.

SET-UP

The starting torque controller has been factory-set for the following starting conditions:

Initial Torque - 30%

Time - 4.0 seconds

The factory settings should be appropriate for most applications, however, if not, adjustments can be made as follows.

Initial Torque - Adjust Initial Torque to the lowest numerical setting to obtain an acceptable starting profile. Heavy loads may require a high initial torque setting.

Time - Set the time adjustment to a numerical setting which will provide a smooth acceleration ramp to full speed.

APPLICATION GUIDELINES

1. Where it is desired to take the jerk out of the system when compared to across-the-line starting.
2. The device is not intended for high inertia loads, i.e., where across-the-line starting exceeds 3 seconds.
3. If your application requires frequent start/stop or reversing, proper co-ordination of overloads is required.
4. On plug reverse applications, additional time is required before the motor actually slows down. Therefore, the total time before the motor stops may be longer than normally encountered with electromechanical starters.

PRODUCT SPECIFICATIONS

Temperature (Operating):	0°C to +50°C		
(Storage):	-40°C to +85°C		
Humidity:	5-95% RH (non-condensing)		
Operating Current:	11A	16A	22A
Maximum Heat Dissipation (Watts):	Unit	15	18
Weight:	0.85lbs	1.7lbs	3.4lbs
	0.4kg	0.8kg	1.6kg
Voltage Ranges (+10%, -15%) 50/60Hz:	100-120	100-120	100-120
	200-240	200-240	200-240
	380-480	380-480	380-480
	500-600	500-600	500-600
Cable Size (Power Terminals):	Wire Size: #14 to #10 AWG (1.5 - 6mm ²)		

TYPICAL CONNECTION DIAGRAMS

FIGURE 1

SINGLE SPEED
3 PHASE

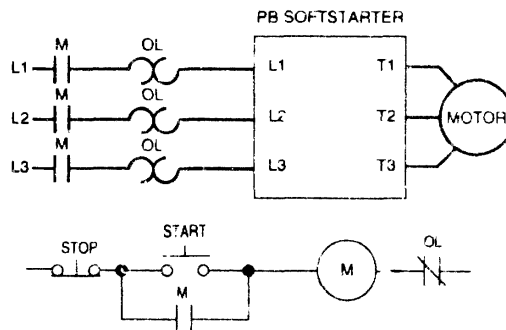

FIGURE 2

SINGLE SPEED
1 PHASE

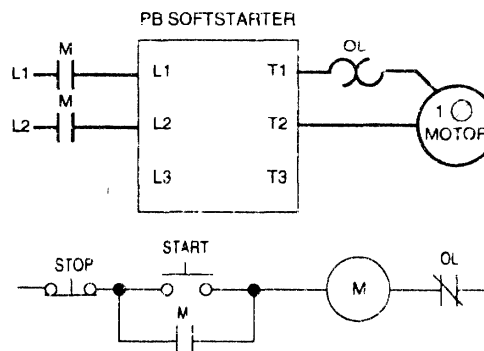
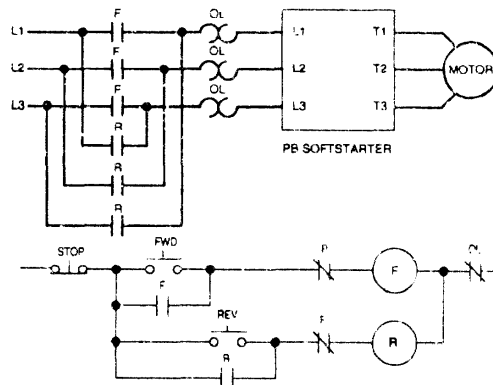

FIGURE 3
REVERSING



Troubleshooting Guide

PROBLEM	POSSIBLE CAUSE	REMEDY
1. Motor starts too fast or motor starts with a jerk.	1A. Initial torque switch set too high for load. 1B. Time switch set incorrectly for load. 1C. Shorted SCR.	1A. Decrease initial torque setting 1B. Increase time setting. 1C. Resistance between L1 & T1 should be zero ohms. 1C. Resistance between L3 & T3 should be zero ohms. 1C. Resistance between L2 & T2 should be greater than 50 ohms. Less than 50 ohms indicates shorted SCR, replace PB.
2. Motor hesitates before starting.	2A. Initial torque switch set too low for load or line variation.	2A. Increase initial torque setting.
3. Motor hums, but will not start.	3A. Missing power phase. 3B. Motor rotor is locked or overloaded. 3C. Defective motor. 3D. Inoperative PB.	3A. Check for open line. 3B. Correct source of stall. 3C. Continuity test motor. 3D. Replace PB.
4. Frequent overload relay (OLR) trips.	4A. Motor overloaded. 4B. Improperly sized overload heaters. 4C. Hard to start (i.e.: high inertia) loads. 4D. Frequent start/stop or reversing operations. 4E. Improperly selected overload relay.	4A. Apply rated load to motor. 4B. Use correctly sized overload heaters. 4C. Review application guidelines. 4D. Increase initial torque setting and/or lower time setting. 4E. Check for proper motor/overload relay co-ordination.

APPROXIMATE DIMENSION & SHIPPING WEIGHTS

FIGURE 4

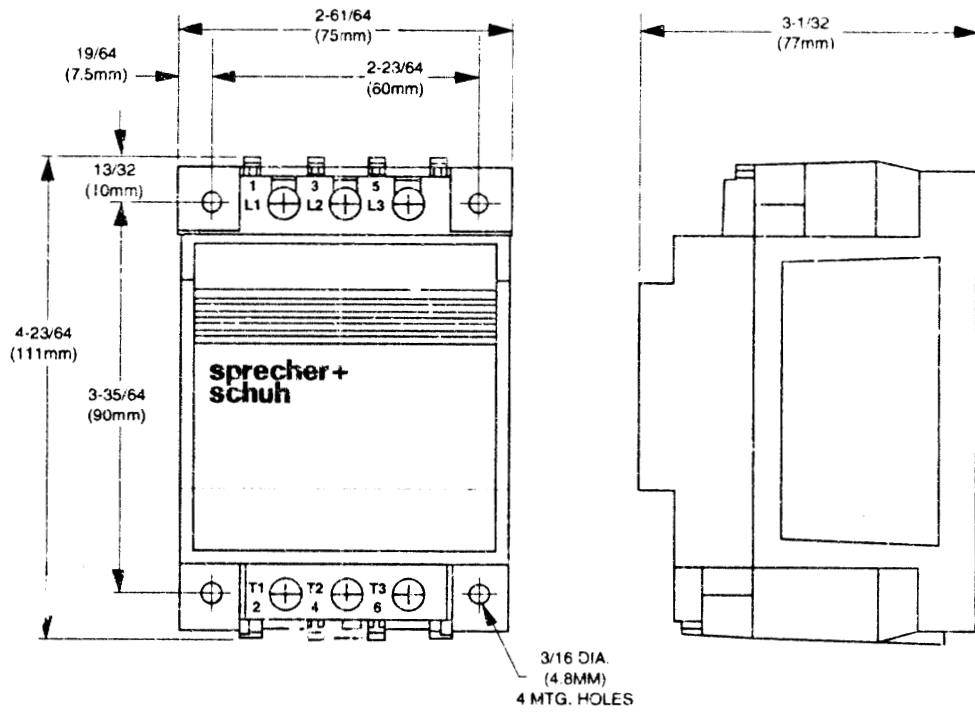
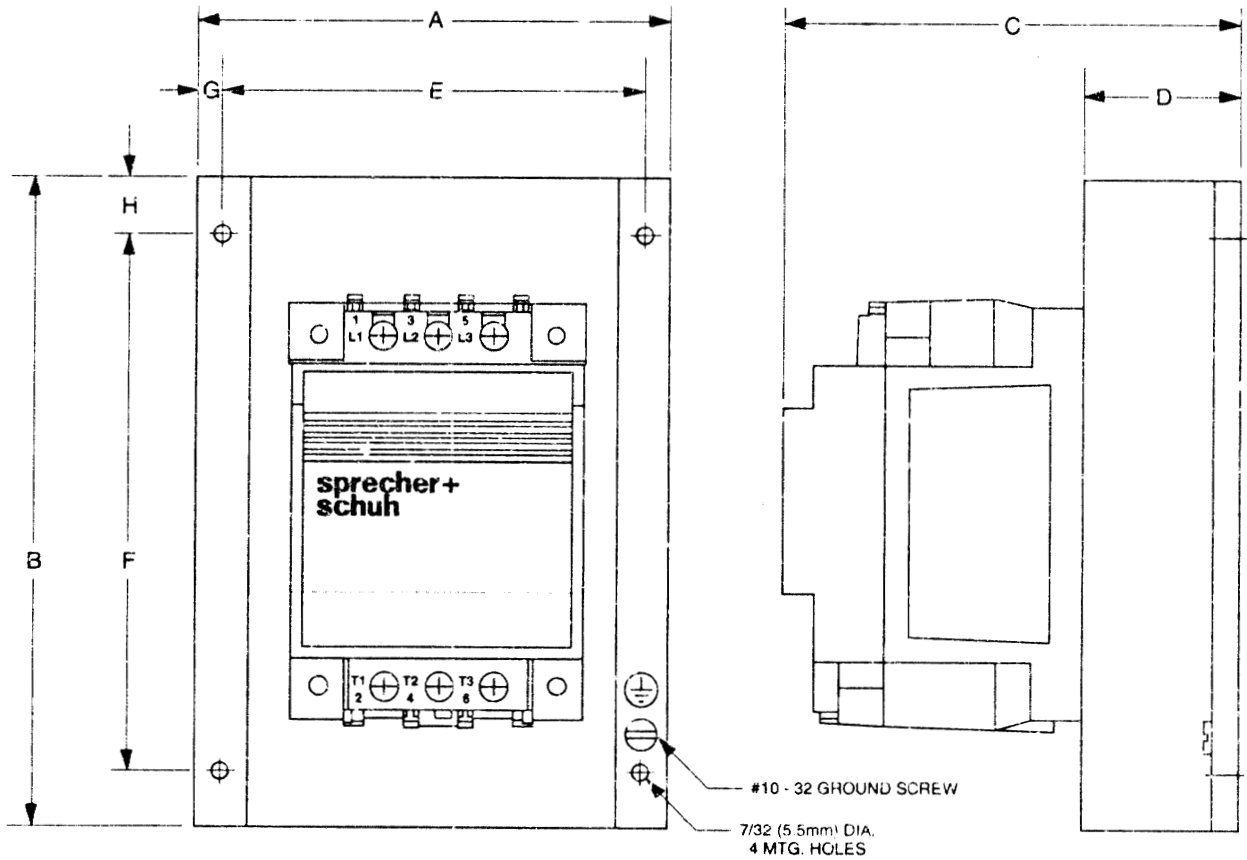

FIGURE 5



CONTROLLER	UNIT	A	B	C	D	E	F	G	H	APPROX. SHIP. WT.
		WIDTH	HEIGHT	DEPTH						
16A CONTROLLER	MILLIMETER	122	127	101	24	110	90	6	18.5	2.25 KG
	INCH	4-3/16	5	3-31/32	15/16	4-21/64	3-35/64	1/4	3/4	5 LBS.
22A CONTROLLER	MILLIMETER	154	180	127	50	140	140	7	20	3.15 KG
	INCH	6-1/16	7-3/32	5	1-31/32	5-33/64	5-33/64	9/32	25/32	7 LBS.