

sprecher + schuh

Attention: To prevent electrical shock, disconnect from power source before installing or servicing. Install in suitable enclosure. Keep free from contaminants.

Achtung: Vor Installations- oder Servicearbeiten Stromversorgung unterbrechen, um Unfälle zu vermeiden. Die Geräte müssen in einem passenden Gehäuse eingebaut und gegen Verschmutzung geschützt werden.

Attention: Avant le montage et la mise en service, couper l'alimentation secteur afin d'éviter tout accident. Prévoir une mise en coffret ou armoire appropriée. Protéger le produit contre les environnements agressifs.

Attenzione: Per prevenire infortuni, togliere tensione prima dell'installazione o manutenzione. Installare in custodia idonea. Tenere lontano da contaminanti.

Atención: Desconectar la alimentación eléctrica antes de realizar el montaje y la puesta en servicio, con el objeto de evitar accidentes. Instalado en una caja o armario apropiado. Proteger el producto de los ambientes agresivos.

CT7N-85...P



CE

IEC/EN 60947-1,-4-1,-5-1
UL 508
CSA 22.2 No. 14

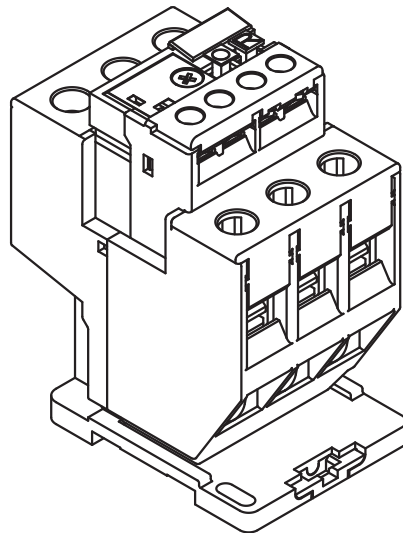

Use 75°C Cu wire only	

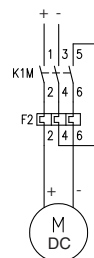
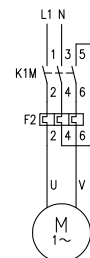

USA / CND

Suitable For Use On A Circuit Capable Of Delivering Not More Than 5000 / 10000 rms Symmetrical Amperes, 600 Volts Maximum.

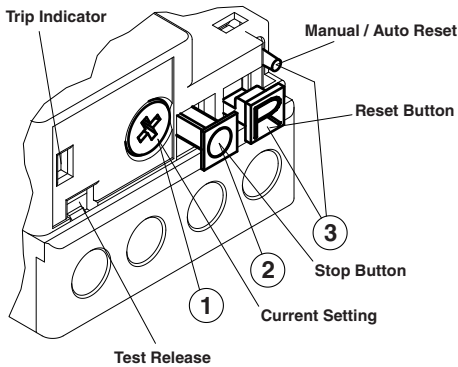

①

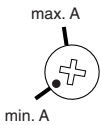

trips at maximum
125 % of current setting
löst bei max. 125 % des
eingestellten Stromes aus
déclenche à max. 125 % de la
valeur du courant ajusté
sganciamento al massimo al
125 % della corrente regolata
sugerencias al máximo
125 % de la configuración actual

②

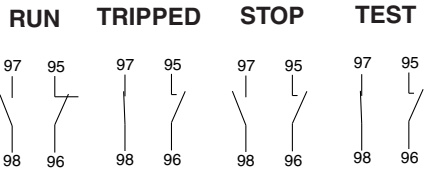
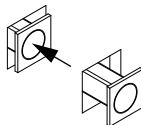

③ RESET



ATTENTION: Do not use automatic reset mode in applications where unexpected automatic restart of the motor can cause injury to persons or damage to equipment.

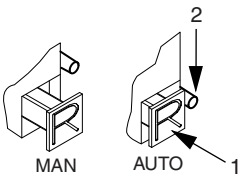

ACHTUNG: Der automatische Rücksetzmodus darf nicht in Anwendungen verwendet werden, in denen der unerwartete Neustart des Motors zu Personen- oder Sachschäden führen kann.

ATTENTION: N'utilisez pas le mode réarmement automatique dans les applications où un redémarrage automatique inattendu du moteur pourrait provoquer des blessures personnelles ou des dégâts matériels.

ATTENZIONE: non usare la modalità di ripristino automatico in applicazioni dove il riavviamento automatico improvviso del motore può provocare infortuni o danni all'apparecchiatura.

ATENCIÓN: No use el modo de reseteo automático en aplicaciones donde el arranque repentino del motor pueda causar lesiones personales o daño al equipo.