

## Installation instruction

**Attention:** To prevent electrical shock, disconnect from power source before installing or servicing. Install in suitable enclosure. Keep free from contaminants.

## Montageanleitung

**Achtung:** Vor Installations- oder Servicearbeiten Stromversorgung unterbrechen, um Unfälle zu vermeiden. Die Geräte müssen in einem passenden Gehäuse eingebaut und gegen Verschmutzung geschützt werden.

## Instruction de montage

**Attention:** Avant le montage et la mise en service, couper l'alimentation secteur afin d'éviter tout accident. Prévoir une mise en coffret ou armoire appropriée. Protéger le produit contre les environnements agressifs.

## Istruzione per il montaggio

**Attenzione:** Per prevenire infortuni, togliere tensione prima dell'installazione o manutenzione. Installare in custodia idonea. Tenere lontano da contaminanti.

## Instrucción de montaje

**Atención:** Desconectar la alimentación eléctrica antes de realizar el montaje y la puesta en servicio, con el objeto de evitar accidentes. Instalado en una caja o armario apropiado. Proteger el producto de los ambientes agresivos.



**KTA7-25/32S-...**

**KTB7-25/32S-...**

**KTC7-25/32S-...**

**KTA7-25/32H-...**

**KTB7-25/32H-...**

**KTC7-25/32H-...**



IEC 60947-1,-2,-4-1

EN 60947-1,-2,-4-1

EN 60079-14

UL 508

CSA C22.2 No. 14

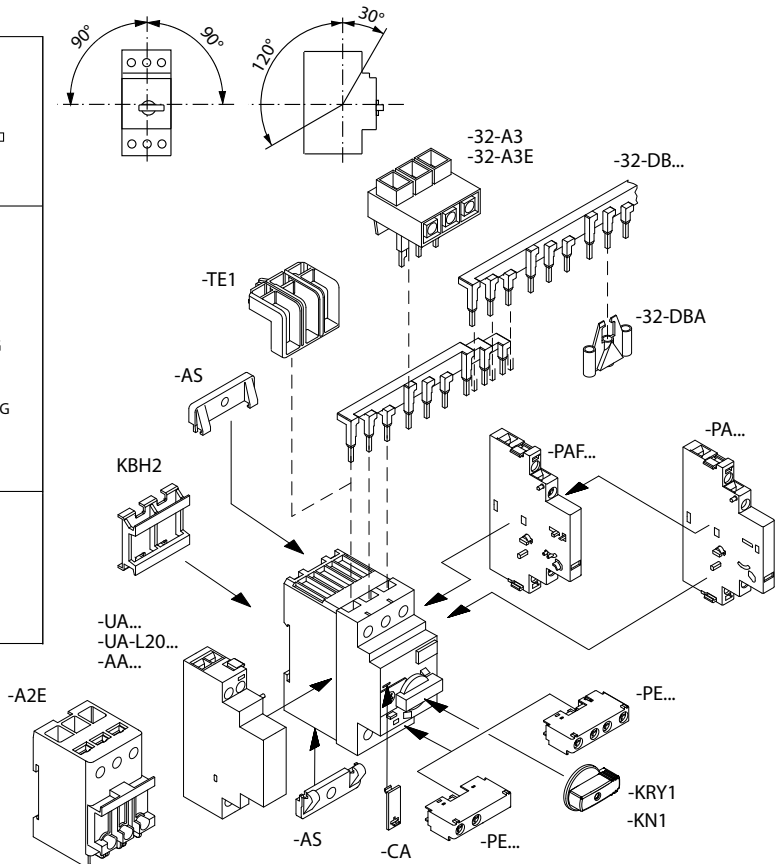
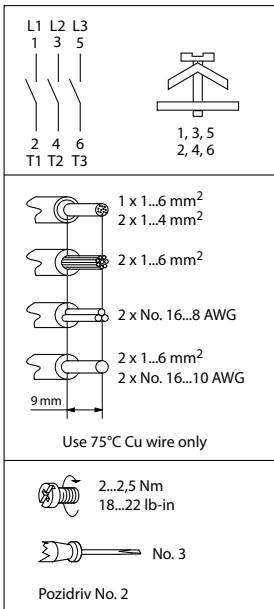

	KTA/B/C/7-25/32S...	KTA/B/C/7-25/32H...
H1	44 (1-47/64)	54 (2-1/8)
H2	62 (2-7/16)	72 (2-53/64)

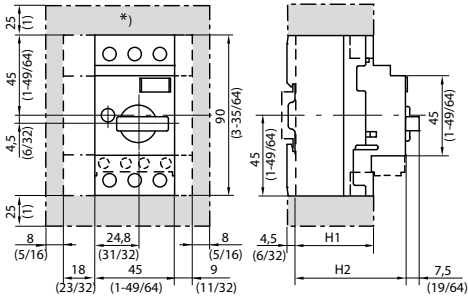

\*) Minimum distance to grounded parts or walls  
 Minimaler Abstand gegen geerdete Teile oder Wände  
 Distance minimale envers pièces mises à terre ou parois  
 Distanza minima per pezzi a massa o pareti  
 Distancia mínima a chasis o paredes

KTB7-25/32S/H do not provide thermal protection for themselves nor for downstream components. A separate protective device against thermal overload must be installed, e.g. an O/L relay as part of a starter combination.

KTB7-25/32S/H beinhalten weder für sich selbst noch nachfolgende Teile thermischen Schutz. Gegen thermischen Überlast muss ein externes Schutzorgan installiert sein, z.B. ein Überlastrelais als Teil einer Starterkombination.

KTB7-25/32S/H ne sont pas autoprotégés et ne comportent aucune protection contre les surcharges thermiques. Il faut donc prévoir des organes de protection externes comme par expl. des relais thermiques ou électroniques dans les ensembles démarreurs moteurs.

KTB7-25/32S/H non prevedono alcun tipo di protezione termica, né per se stessi né per i componenti a valle. Pertanto sarà necessario installare un dispositivo di protezione termica separato, quale ad esempio un relè di sovraccarico integrato nel gruppo di avviamento.

KTB7-25/32S/H carecen de protección térmica propia y para los componentes subsiguientes. Se debe instalar por separado un dispositivo de protección para sobrecargas térmicas, como por ejemplo, un relé de sobrecarga que forme parte de un arrancador de combinación.

### Wiring Diagrams for 1- or 2-Phase Application

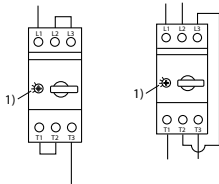

### For 1- or 2-Phase Motor Application

- Set to 105% of motor current.  
 Stellen Sie 105% des Motorstromes ein.  
 Régler à 105% de la valeur du courant moteur.  
 Regolare a 105% della corrente del motore  
 Ajustar a 105% de la corriente del motor.



**Warning:**  
Do not set outside scale !

**Warnung:**  
Nicht ausserhalb Skala einstellen !

**Attention:**  
Défense d'ajuster le courant en dehors de la plage indiquée !

**Attenzione:**  
E vietato di regolare la corrente fuori dal campo di taratura !

**Atención:**  
¡Prohibido de regular la corriente fuera del campo de la escala !

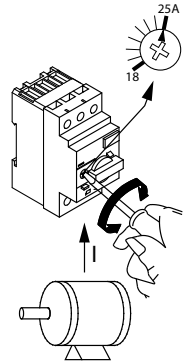

### For UL Control Transformer Protection

- The device is to be installed only on the load side of branch circuit protection.
- Set the current adjustment not more than the rated input current of the control transformer.
- Use only in the specific supply voltage system as marked on the device.

### Motor Protection / Circuit Breaker

This device meets the requirements of IEC 60947-2 as a circuit breaker.

It is cULus listed (UL and CSA approved) as:

- A Manual Motor Controller with optional approvals for Group Motor, Motor Disconnect and Tap Conductor Protection.
- A Manual, Self-Protected Combination Motor Controller (Construction Typ E).

All installations, commissioning and maintenance must be carried out by qualified personnel, taking local regulations into account.

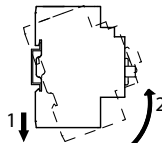
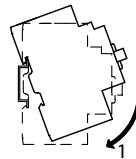

-32-A3  
-32-A3E

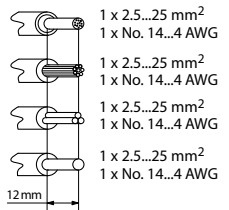

Use 75°C Cu wire only

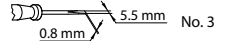
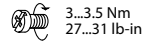

Pozidriv No. 2