



Type E Combo With Powerful Features and Superior Protection

CLT7 Three Component Starters

The CLT7 across-the-line 3-component starters and CLUT7 reversing starter assemblies provide all the benefits of the 2-component CL7 and CK7 starters and more! These new starters can now manage the following applications:

- Multiple motor starter panels that require individual manual overload relay resets on the door
- Class 15, 20, or 30 overload relays for heavy duty starting
- Applications requiring CEP7 side mount modules:

- Remote overload relay reset
- Stall protection
- Ground Fault protection
- PTC thermistor relay functions
- Profibus communications
- Ethernet communications (available May 2009)

A Powerful COMBO

The CLT7 offers these functions and more:

- 2ms operational tripping speed of the KT7 under short-circuit condition beats fuses
- Type 1, 4, 4x, 12, IP66 simple through-the-door APPROVED disconnect handles
- CA7 contactor with proven reliable, flexible optional accessories
- State-of-the-art electronic motor protection which is the benchmark of the industry

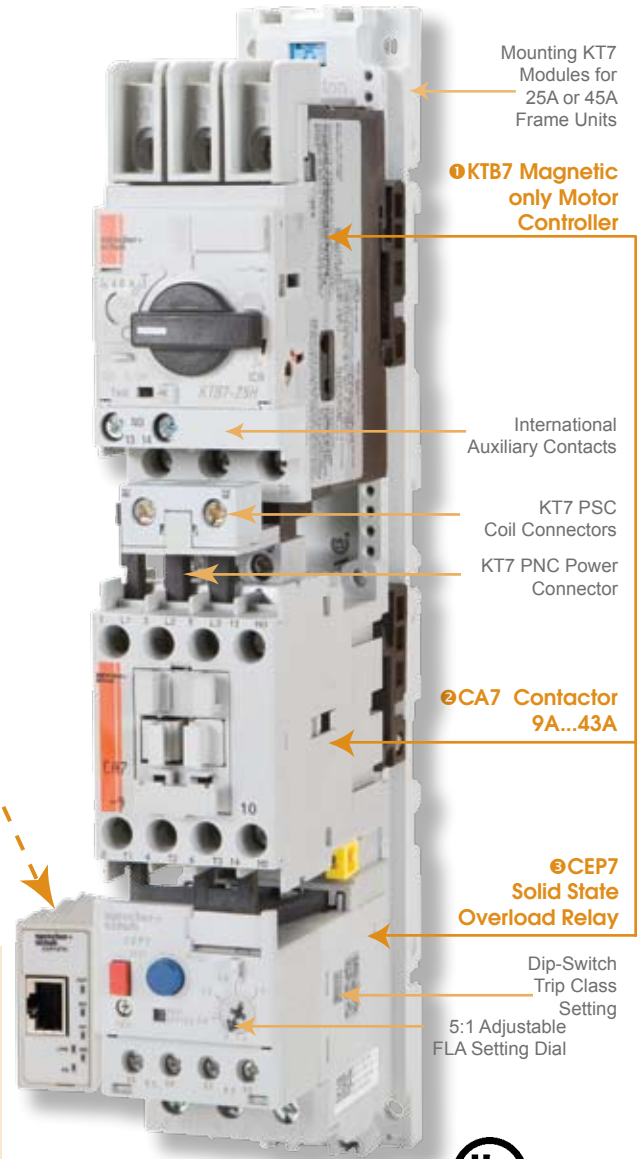

1 KTB7 Magnetic Only Motor Circuit Controller

KTB7 Motor Controller device leads the industry in short-circuit withstand ratings (KAIC) with a 2ms tripping response time. The KT7 provides current-limiting short-circuit protection up to 65kA.



2 CA7 Series Contactor

The compact CA7 Contactor modular design provides maximum performance and flexibility and is easy to use. Combined with KT7 can be selected for applications up to 30HP @ 460V.



3 CEP7 2nd Generation Overload Relay

The CEP7 offers superior motor protection at an affordable price. Thus, solid state overload relay is the benchmark of accuracy and features.

Approval Background

Combo is not just a slang electrical term for Combination Motor Starter. Combo means you have UL Approval to perform four functions:

- Branch Short-circuit Protection
- Means of Disconnect
- Motor Controller
- Overload Relay Protection

NEC 430-52 C-Option 6 recognized the Self-protected Combination Motor Controllers as approved method of providing branch circuit protection, controller, overload and circuit disconnect all in one compact device. The KTA7 was designed for normal starting of squirrel cage motors with an inrush of $6 \times \text{FLA} = \text{LRA}$. Similarly, the KTC7 was designed for starting of high efficiency squirrel cage motors with inrush of $9...11 \times \text{FLA} = \text{LRA}$.

The term Type E devices was derived from UL 508 Standards Part IV for Combination Motor Controllers where they expanded the existing fusible and circuit breaker (Types A...D) Combo's to include the Type E Self-Protected Manual Combination Controller. Then we added the CA7 contactor and assembled the CL7 or CK7 which is a 2-component starter or Type F assembly giving remote control.

Under NEC 430-52 C-Option 7, a magnetic only motor circuit controller can be combined with a contactor and an overload and tested as a Type E assembly. UL has tested and approved KTB7 Magnetic only Motor Circuit Controller to be combined with CA7 Contactors and CEP7 Overload Relays resulting in the most powerful and, yet, compact Combo in the market place today!

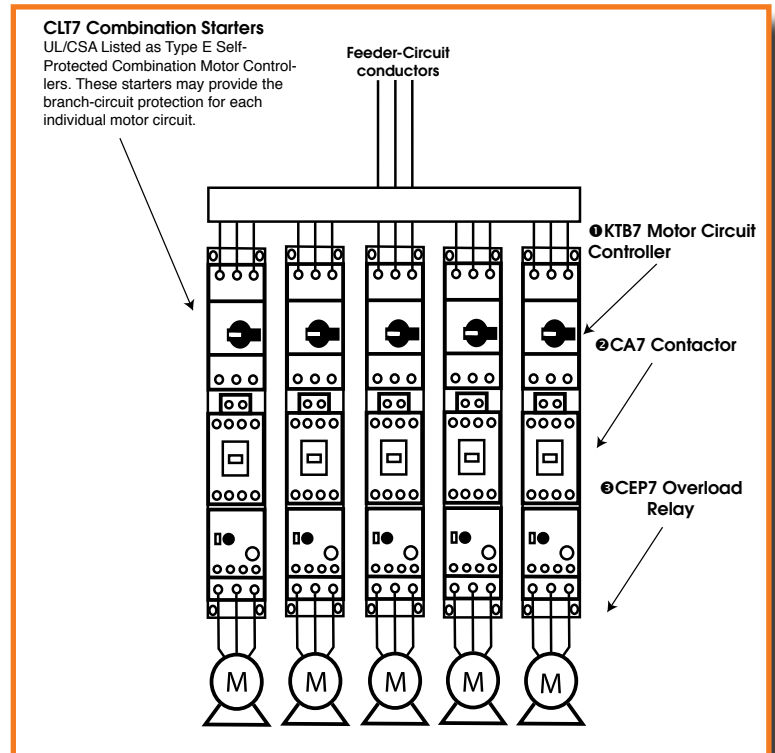

	Typical Three Phase [HP]				Assembly Components*			Self-Protected Combination		
	200V	230V	460V	575V	Self-protected Motor Controller	Contactor	Electronic Overload	208V-240V	480Y / 277V	600Y / 347V
KTB7 + CA7 + CEP7 UL Assemblies (CLT7 / CLUT7)										
KTB7-25S Standard Interrupting Capacity	~	~	~	~	KTB7-25S-0.4A	CA7-9	CEP7-ED1AB	65	65	47
	~	~	~	~	KTB7-25S-0.4A	CA7-9	CEP7-EEAB	65	65	47
	~	~	~	1/2	KTB7-25S-1.0A	CA7-9	CEP7-ED1BB	65	65	47
	~	~	~	1/2	KTB7-25S-1.0A	CA7-9	CEP7-EEBB	65	65	47
	1/2	1/2	1	~	KTB7-25S-2.5A	CA7-9	CEP7-ED1CB	65	65	~
KTB7-25H High Interrupting Capacity	1/2	1/2	1	~	KTB7-25H-2.5A	CA7-9	CEP7-ED1CB	65	65	~
	1/2	1/2	1	~	KTB7-25H-2.5A	CA7-9	CEP7-EECB	65	65	~
	1/2	1/2	1	1-1/2	KTB7-25H-2.5A	CA7-23	CEP7-ED1CB	65	65	30
	1/2	1/2	1	1-1/2	KTB7-25H-2.5A	CA7-23	CEP7-EECB	65	65	30
	3/4	3/4	2	3	KTB7-25H-4.0A	CA7-23	CEP7-ED1CB	65	65	30
	3/4	3/4	2	3	KTB7-25H-4.0A	CA7-23	CEP7-EECB	65	65	30
	2	3	5	7-1/2	KTB7-25H-10A	CA7-30	CEP7-EEED	65	65	30
	3	~	10	10	KTB7-25H-16A	CA7-30	CEP7-EEED	65	65	30
KTB7-45H High Interrupting Capacity	5	7-1/2	15	~	KTB7-25H-25A	CA7-30	CEP7-EEED	65	65	30
	5	7-1/2	15	20	KTB7-45H-25A	CA7-30	CEP7-EEED	65	65	30
	7-1/2	10	20	20	KTB7-45H-32A	CA7-30	CEP7-EEFD	65	65	30
	7-1/2	10	20	20	KTB7-45H-32A	CA7-37	CEP7-EEFD	65	65	30
	10	10	25	~	KTB7-45H-45A	CA7-37	CEP7-EEFD	65	65	~
	10	15	30	~	KTB7-45H-45A	CA7-43	CEP7-EEFD	65	65	~

*For complete CLT7/CLUT7 part numbers, see SSNA 9000 catalog pages F56 - F57.